

**OPTICS**  
**DIFFRACTION**  
**Practical 10**  
**FRESNEL AND FRAUNHOFER DIFFRACTION**

**1 Introduction**

The difference between Fresnel diffraction (near-field diffraction) and Fraunhofer diffraction (far-field diffraction) is determined by the position of the observation point with respect to the object at which diffraction of light occurs (diaphragms, screens, etc.). Consider diffraction of light on by an aperture of radius  $R$  (Fig. 1). If the observation point  $O$  is located relatively close to the hole, or, more precisely, if

$$b \leq \frac{R^2}{\lambda}, \quad (1)$$

( $b$  is the distance from the aperture), then one says that the conditions for observing Fresnel diffraction are satisfied. In this case, at least one Fresnel zone is visible through aperture:

$$R \geq \sqrt{\lambda b}, \quad (2)$$

$\sqrt{\lambda b}$  is the radius of the first Fresnel zone under condition  $a \rightarrow \infty$ . If

$$b \gg \frac{R^2}{\lambda}, \quad (3)$$

in which case the radius of the first Fresnel zone is much larger than the radius  $R$  of the aperture, then one speaks of Fraunhofer diffraction.

**Part 1. Fresnel diffraction**

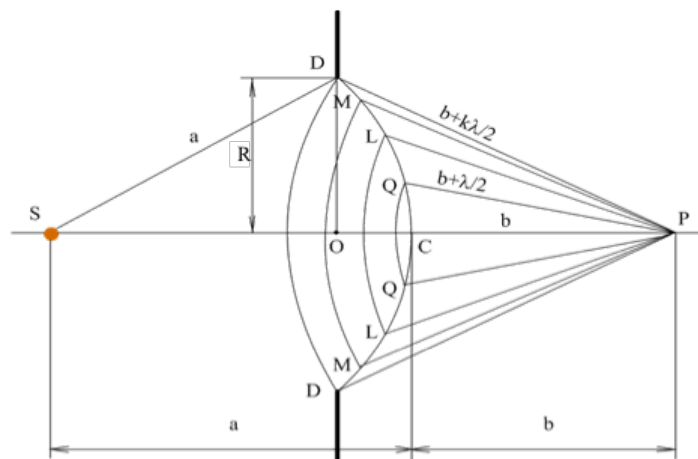

Fig. 1

In the first part, the diffraction of light waves by a circular aperture is studied, while the choice of the observation point satisfies condition (1).

$$n = \frac{R^2(a+b)}{\lambda ab}. \quad (4)$$

The number of zones visible through the aperture can be calculated by calculating the number of zones  $n$  (from the diffraction pattern) and measuring the distances  $a$  and  $b$ . Then one can calculate the wavelength  $\lambda$  of the light wave.

**2 Experimental setup**

A schematic of the experimental setup is shown in Fig. 2. Light from the source (a mercury lamp 1) with a light filter 2 is converged by means of a condenser 3 into a very small circular hole 4, which acts as a point source  $S$ . The hole 4 is made in aluminum foil mounted in a special frame on the tube. A cover 5 with a circular diffraction aperture of radius  $R$  is put on the opposite end of the tube.

The positions of the lamp, condenser and tube on the optical bench are fixed while tuning the setup, so one cannot change them during the experiment. The diffraction pattern is observed through the eyepiece 6, which can be moved along the optical bench. The eyepiece holder has a pointer that allows measuring the distance  $b$  along the ruler (with an accuracy of up to 1 mm).

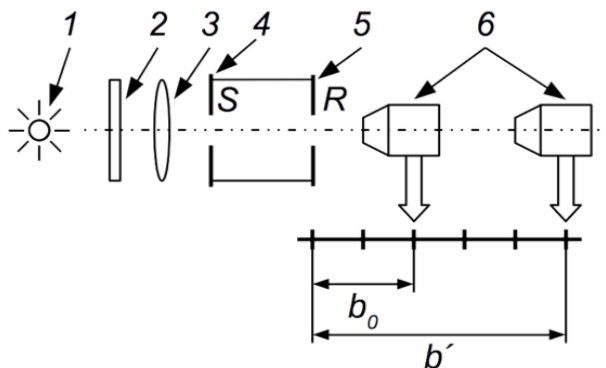

Fig. 2.

### 3 Measurements and data processing

Turn on the mercury lamp, following the proper procedure, which should be familiar to you from **Practical 6**. Put a light filter in the path of the light beam to extract from the emission spectrum a specific wavelength  $\lambda$ ; the value of  $\lambda$  is indicated on the light filter. Put the diffraction aperture 5 of radius  $R$  on the end of the tube, and moving the eyepiece along the optical bench, observe the change in the diffraction pattern.

First, move the eyepiece to the end of the optical bench and then push it closer to the aperture; mark the position of the eyepiece at which the dark point (two Fresnel zones are open) first appears in the center of the picture.

#### Task 1. Determine the radius of the diffraction aperture

Using the values of  $b'$  and  $b_0$ , (see Fig.2) calculate the values of  $b = b' - b_0$  which correspond to all the observed patterns. Knowing  $a$ ,  $\lambda$  and the number of open zones  $n$ , calculate for each  $n$  the radius  $R$  of the aperture from equation (4). The value of  $a$  is indicated on the setup.

#### Task 2. Determination of the passband of the light filter

Using the light filter with the unknown passband (the wavelength range, which passes through the filter) and the radius  $R$  from task 1, repeat the set of the measurements from task 1 and determine from equation (4) the passband of the filter. Put down the results in a table. Your report must contain sketches of the observed patterns corresponding to two, three, etc. open Fresnel zones. ( How many zones is it reasonable to go through in this Practical?)

## Part 2. Fraunhofer diffraction

### 2 Experimental setup

A schematic of the setup is shown in Fig. 3. The light source 1 is the same mercury lamp as in Part I. The filter 2, the condenser 3 and the stop 4, which plays the role of a point source, are made in a similar way. To obtain a parallel light beam, the stop 4 is located exactly in the focus of the lens 5 mounted at the end of the tube. Various diffraction objects can be placed on the lens rim 6: a circular aperture, a rectangular slit, a set of circular apertures, etc. Diffraction patterns are viewed through the telescope 7, tuned to infinity. The visual tube of the telescope is equipped with an ocular micrometer 8, which makes it possible to measure the necessary distances while observing diffraction patterns. The displacement of the cross-pointer of the micrometer can be measured on its' scale with an accuracy of 0.01 mm.

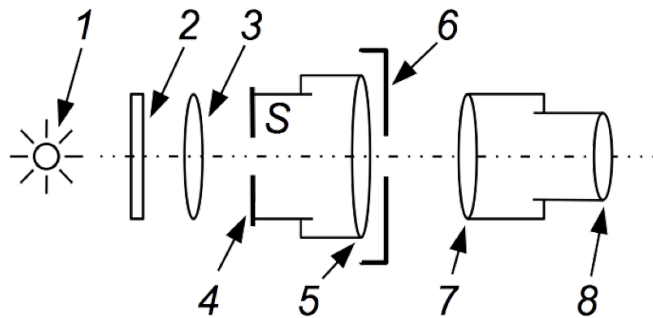

Fig. 3

### 3 Measurements and data processing

Position the telescope 7 so that a bright and sharp image of the stop is visible at the center of the field of view. Make sure that the cross-pointer of the micrometer can be placed by rotating the drum exactly on the image of the inlet. The collimator - the tube with the stop 4 and the lens 5 is already tuned to infinity and cannot be adjusted.

#### Task 1. Diffraction by a single circular aperture

Place a light filter in front of the condenser 3 and mount the iris diaphragm on the lens rim. Gradually changing the aperture opening, observe how the image of the stop changes because of the light beam restriction. Put a cover with a single circular aperture on the lens rim and sketch the observed picture in your notebook. Repeat the same procedure with a rectangular slit. Indicate the orientation of the rectangular slit, next to the diffraction pattern. The comparison of the figures should show which side of the rectangle slit corresponds to the high alternation frequency of the diffraction maxima.

#### Task 2. Diffraction by a set of circular apertures

Put a cover with a lot of randomly located circular apertures on the lens rim - the usage of such an object will allow observing a diffraction pattern, almost identical to the picture from a single circular aperture, but with much greater illumination.

Tune the cross-pointer of the micrometer to the different parts of the diffraction pattern and measure the positions of the maxima and minima of illumination by recording the corresponding number of divisions on the ocular micrometer scale. Using the equations below for the case of diffraction of plane waves by a circular aperture, determine the wavelength of the light wave transmitted through the light filter from the mercury lamp emission spectrum:

$$\text{for minima } R \sin(\varphi)_{min} = 0.61 \lambda; 1.12 \lambda; 1.68 \lambda; \quad (5)$$

$$\text{for maxima } R \sin(\varphi)_{max} = 0 \lambda; 0.81 \lambda; 1.33 \lambda; 1.85 \lambda; \quad (6)$$

The ocular micrometer allows measuring the linear dimensions of a picture in the focal plane. To find the sine of the diffraction angles, take the ratio of the displacement of the cross-pointer  $\Delta x$  to the focal length of the objective lens of the telescope  $f$ :

$$\sin(\varphi) \approx \tan(\varphi) = \frac{\Delta x}{f}, \quad (7)$$

The radius of the aperture  $R$  and the focal length of the telescope objective lens  $f$  are indicated on the setup. Put down your results into a table.

#### 4 Questions

1. Is it possible to observe diffraction patterns by apertures of radii of the order of several centimeters?
2. How will the diffraction pattern change, if an opaque obstacle with an aperture of radius  $R$  in a Fresnel's setup is replaced with a transparent obstacle with a black circle of the same radius  $R$ ?
3. How many Fresnel zones have been opened by an aperture, if a bright spot first appears at the center of the pattern after a dark point?
4. Why is the telescope used in the Fraunhofer diffraction setup instead of the eyepiece?
5. How will the diffraction pattern change if the telescope, which is tuned to infinity, is moved away from the lens?
6. How will the diffraction patterns differ for apertures of different radii?
7. If one carefully examines the diffraction pattern for a set of apertures and compares it with the diffraction pattern by a single aperture, one will notice some difference in those patterns (besides a significant difference in illumination). What is the difference between those patterns? How can one explain this difference?