

UNIT

1

## Introduction to Measuring System

### Learning Objectives:

- System of Units
- Need of electrical instruments
- Different electrical quantities to be measured and their practical units
- Familiar with various electrical instruments and their functions
- Development of SI system
- Multiplication factors and their necessity in Electrical technology
- Classification of Measuring Instruments

### 1.1 Introduction

The science of measurements is an integral part of the development of physical science. Most of the laws of electricity were uncovered during the eighteenth and nineteenth centuries and during this short period there has been a phenomenal growth in electrical engineering.

Many of the instruments used today are essentially the same as those designed originally by the scientists. The performance of the instruments are improved and made more accurate.

Measurement is essentially a process in which the measured magnitude of quantity is determined in comparison with another similar quantity.

## 1.2 Units

Any quantity that can be measured is called a physical quantity. In science we come across a large number of quantities of different kinds such as length, mass, time, velocity, acceleration, force, work, power, current, resistance etc. To measure any physical quantity a standard of the same quantity is essential and this is called a unit.

## 1.3 Fundamental Units and Derived Units

Until recently length, mass and time are considered as fundamental quantities and standard measures employed to measure these quantities are the fundamental units.

### Fundamental Quantity

- (a) Physical quantity - the quantity which is independent of any other quantity, is fundamental quantity
- (b) Fundamental unit - the unit of a physical quantity, which is independent of any other quantities, is called a fundamental unit.
- (c) Derived Quantities - the physical quantities which can be derived from other physical quantities are called derived quantities.
- (d) Derived Units - the units of physical quantities, which can be expressed in terms of fundamental units, are called derived units.

For example area, pressure, density and speed are derived quantities and their units square meter, pascal, kilogram, metre and meter second are derived from the fundamental units

## 1.4 Systems of Units

To measure the fundamental quantities *length, mass and time* there are three standardized systems of units. They are:

- 1) FPS System
- 2) CGS System
- 3) MKS System

**Fundamental quantities and their units**

System	Units		
	Length	Mass	Time
1. FPS	Foot	Pound	Second
2. C.G.S.	Centimetre	gram	Second
3. MKS	Metre	Kilogram	Second

**1.5 S.I. System**

International system of units is called S I system In this length, mass, time, thermo dynamic temperature, illuminating power (luminous intensity) strength of the electric current, quantity matter are taken as fundamental quantities. In addition to these fundamental quantities plane angle and solid angle are taken as supplementary quantities.

**1.6 Fundamental quantities and their units (In SI System)**

Fundamental Quantity	Unit	Symbol
Length	Metre	m
Mass	Kilogram	Kg
Time	Second	S
Thermodynamic Temperature	Kelvin	K
Illuminating power	Candela	cd
Luminous Intensity	lux	lux
Strength of electric current	Ampere	A
Quantity of matter	mole	mol
Plane angle	radian	rad
Solid angle	Steradian	Sr

## 1.7 Multiplication Factors of Units

The multiples and submultiples of a units are written by adding suitable multiplication factor as prefix to the unit.

The names and symbols of various multiplication factors are shown in the table below

Multiplication Factor	Name	Symbol
$10^{18}$	Exa	E
$10^{15}$	Peta	P
$10^{12}$	Tera	T
$10^9$	Giga	G
$10^6$	Mega	M
$10^3$	Kilo	K
$10^2$	Hecto	H
10	Deco	da
Multiplication Factor	Name	Symbol
$10^{-1}$	Deci	d
$10^{-2}$	Centi	c
$10^{-3}$	Milli	m
$10^{-6}$	Micro	$\mu$
$10^{-9}$	Nano	n
$10^{-12}$	Pico	p
$10^{-15}$	Femto	f
$10^{-18}$	atto	a

(1) The multiplication factors  $10^{-2}$ ,  $10^{-1}$  and  $10^2$  are avoided as far as possible.

(2) It is preferable to express quantity as a coefficient of  $10^3$ . For example instead of writing  $2.2 \times 10^2$ , it is preferable to write  $0.22 \times 10^3$

(3) Compound multiplication factors should be avoided  $5 \times 10^{12}$  should be written as 5T but not as 5GKS

### 1.8 Units Names after Scientists

In SI system some of the important units are named after scientist some of them are given below

Quantity	Units	Symbol
Force	newton	N
Energy	joule	J
Power	watt	w
Pressure	pascal	pa
Frequency	hertz	Hz
Electric potential	volt	V
Electric charge	coulomb	C
Capacitance	fared	F
Magnetic flux	weber	wb
Electromagnetic induction	henry	H
Electric resistance	ohm	$\Omega$
Luminous flux	lumen	lm

### 1.9 Importance Of Measuring Instruments

The importance of measurements can be noticed by any body in everyday life. Measurements are the basis for the understanding of all kinds of deals. The trade of goods is entirely based on well-known quantities.

Measurement of absolute standards are is extremely complicated and time-consuming. Therefore, secondary standards are used which are move convenient in calibrating other apparatus. These secondary standards are checked periodically in comparison with absolute standards.

### 1.10 Various Electrical Instruments and their Functions

In the field of Electrical Technology, several electrical quantities are to be measured. The measurement of various electrical quantities will help the technician/user to monitor the performance of electrical equipment or system. If, measured value is different than the rated value, there may be fault in the equipment/system.

Hence, various parameters of a equipment to be monitored and measured frequently in order to improve the system and to avoid any fault/accident before actually it occurs.

### Basic Electrical Instruments and their functions

Electrical Instrument	Electrical Quantity	Units
1. Voltmeter (V)	Voltage (V)	Volts (V)
2. Ammeter (A)	Current (I)	Amps (A)
3. Watt meter (W)	Power (P)	Watts (W)
4. Energy meter (kwh)	Energy (E)	Units, Kwh
5. Ohm meter	Resistance (R)	Ohms ( )
6. Multi-meter (AVO)	Current, Voltage, Resistance	Amps, Volts, ohms.
7. Frequency meter	Frequency (f)	Heartz (Hz)
8. Tachometer	Speed of motor	revolutions per minute (rpm)
9. Clamp meter	Current (I)	Amps (A)
10. Megger	Resistance (R)	kilo ohms, mega ohms

### Key Concepts

Need of Electrical Instruments

International System of Units

Electrical quantities and units

### Activity

1. Identify and selecting the particular electrical instrument and record current and voltage
2. Applying the multiplication factors

---

**Short Answer Type Questions**

1. Define fundamental units and derived units.
2. Write multiplication factors for 1000,10,00,000 and 1/1000?
3. What is SI system?
4. List the fundamental quantities in SI system.
5. Name any four electrical instruments and their functions.
6. Convert the following  
10 KV into Volts                      50 MW into kilo watts  
25 kilo ohms to ohms    75 milli amps to amperes.

---

**On the Job Training/Project Oriented Questions**

1. Identify the Voltmeter Ammeter and Wattmeter.
2. List various instruments used in OJT centre.
4. Application of Kilowatts, Megawatts and other multiplication factors

UNIT

**2**

## Indicating Instruments

### Learning Objectives:

- Types of indicating instruments
- Working principles of indicating instruments
- Basic requirements of Indicating instruments.
- Concept on ammeter, voltmeter and wattmeter
- Moving coil and Moving Iron Instruments
- Dynamometer type and Induction type instruments

### 2.1 Introduction

The fundamental quantities of electrical engineering such as current, voltage, power, energy, frequency etc., have to be measured with the help of instruments for the purpose of computing the system efficiency and stability.

The instruments which are designed to measure these quantities are called measuring instruments. These instruments show the electrical quantity on its scale by a pointer. Basically they have a sensor, operating and display units. Hence they are also called indicating instruments.



## 2.2 Classification of Measuring Instruments

The electrical measuring instruments can be classified as below

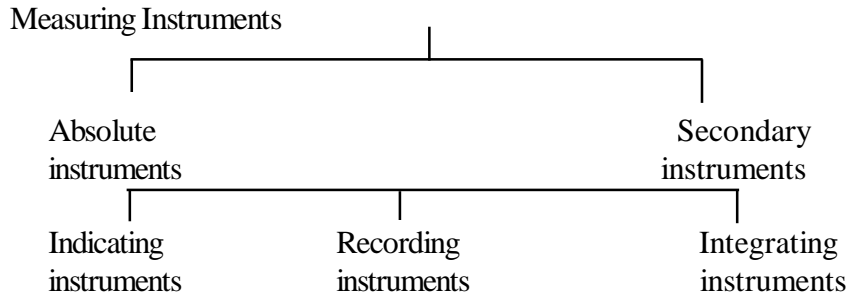

### 2.2.1 Absolute Instruments

Absolute instruments show the quantity to be measured in terms of instruments constant and its deflection and they require no comparison with any other standard instruments.

*Tangent Galvanometer, Raleigh Current and Absolute electrometer* are examples of absolute instruments. They are mostly used in laboratories as standardising instruments.

### 2.2.2 Secondary Instruments

Secondary instruments are those which gives the value of the quantity on its scale or its display unit directly by a pointer. The scale is calibrated by comparison with absolute instruments. Most of the measuring instruments, which are generally used are of “Secondary Type”.

The ordinary Voltmeter, Ammeter, Energy meter are examples for Secondary instruments

### 2.2.3 Indicating instruments

Indicating instruments are those which indicate the magnitude of the instantaneous value being measured by means of a pointer over a calibrated scale. The indication of pointer also change with respect to time giving no scope to know the previous value.

Ammeter, Voltmeter, Wattmeter, Frequency meter, Power factor meter etc... fall under this category.

### 2.2.4 Recording instruments

The instruments which not only read the instantaneous value but also make a record continuously is called Recording instruments .The magnitude of the

quantity is recorded on a paper for certain period of time. In such instruments, the moving system carries an inked pen which touches lightly a sheet of paper wrapped round over a uniformly rotating drum.

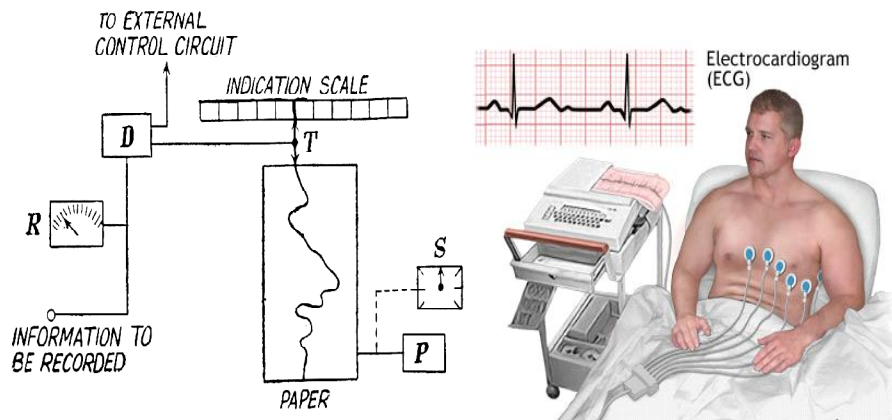

**Fig 2.1 Recording Instruments**

These instruments are generally used in power houses and factories where continuous information is required about the changes in magnitude of the electrical quantity, such that to keep them within well specified limits

### 2.2.5 Integrating Instruments

These instruments measures and registers the total quantity of electricity in a circuit over a specified time. It gives cumulative value of electrical quantity.

Eg: Ampere-hour, meter, Energy meter .

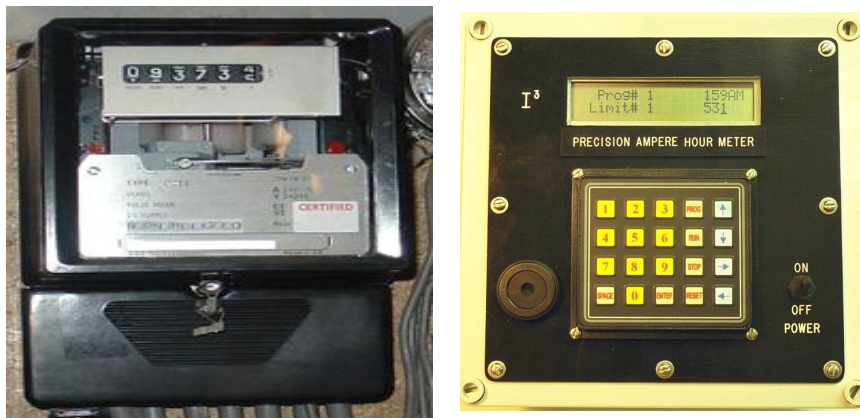

**Fig 2.2 Integrating Instruments**

### 2.3 Effects of Electric Current Utilized In Measuring Instruments

The principle of operation of measuring instruments depend upon the various effects of electric current used in their operation. They are classified as in the table shown below.

Effects used	Type of measurements	Instruments utilizing these effects
Magnetic Effect	Current, Voltage, Power and Energy on both A.C. and D.C. System.	Ammeter, Voltmeter, Integrating meters and other electrical instruments
Thermal effect	Current, Voltage on both A.C. and D.C. system	Ammeter, Voltmeter
Electro magnetic Induction Effect	Voltage, Current, Power energy in A.C. system	Voltmeter, Ammeter, Watt meter energy meter
Chemical Effect	Ampere hours in D.C. System	Voltmeter, Ammeter
Electro Static effect	Voltmeter on both A.C. and D.C. System	Voltmeter

### 2.4 Main parts of Indicating Instruments

Indicating instruments are those which indicate the value of the quantity under measurement. The main parts of indicating instruments are.,

1. Pointer.
2. Pre Calibrated Scale.
3. Moving system with spindle, pivoted in jewelled bearings.
4. Deflecting or operating torque.
5. Controlling or restoring torque.
6. Damping torque.

### 2.4.1 Pointer and scale

The shape and size of the pointer normally depends on the type and size of instruments, usually aluminium tube or strip is used as a material for pointer. The end of the pointer is flattened to the shape of an arrow head and is made to move over a mirror and graduated scale.

The mirror helps in avoiding parallax. The arm of the pointer usually has a double bend to adjust the arrowhead in level to the scale. A small counter weight is attached at the tail end for balancing.

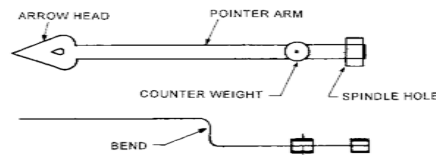

**Fig. 2.3 Different types of pointers**

A clearly marked graduated scale is attached to the case over the pointer. The length of the scale depends upon the length of the pointer and the angle to which it can rotate for full scale deflection.

The scale is printed on a stiff cord usually glazed and white background and block making.

There are two types of scales used in indicating instruments, namely *uniform scale* and *nonuniform scale*. In uniform scale, each division is equally divided. This type of scale is used in moving coil instruments.

The non-uniform scale is cramped at ends and broadly divided in middle part of the scale. We can see this type of scale in moving iron instruments and a.c. measuring instruments.

### 2.4.2 Torques of Indicating Instruments

In most of the indicating instruments three distinct torques are required for operation. They are

- a) A torque to move the pointer from its zero position in same proportion to the magnitude of the quantity being measured. This torque is called *deflecting torque*.
- b) If the pointer has to stop at a value indicating the magnitude of the quantity, there should be an equal and opposite torque at that instant to keep the pointer in stable position. This torque is called *controlling torque*.

- c) When two torques exist in opposite directions, oscillation results due to which the pointer takes some time equal to the oscillation alternation time to set into stable position. To bring the pointer to rest, at the quickest possible time, another torque acts in the directions opposite to the motion of the pointer at the deflected position. It is called damping torque.

### 1. Deflecting Torque ( $T_d$ ) or Deflecting Force

The deflecting torque causes the moving system of the instrument to move from its initial zero position. The magnitude of the deflecting torque depends upon the magnitude of the measurable quantity.

The torque is produced by the effects of electric current such as magnetic, electro-magnetism, heating, electrostatic etc. The method of production of deflecting torque and its relation to the measurable quantity depends upon the type of instrument.

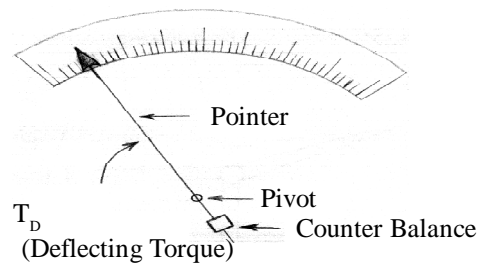

Fig 2.4 The Action of Deflecting Torque

### 2. Controlling Torque ( $T_c$ ) or Controlling Force

The force acting on a moving system, in opposite direction to deflecting torque and makes the pointer stable at its final deflected position is called Controlling Torque or Controlling Force. The pointer will try to rotate as motor in absence of this torque. It also brings the pointer back to zero position, after disconnecting the meter from the circuit.

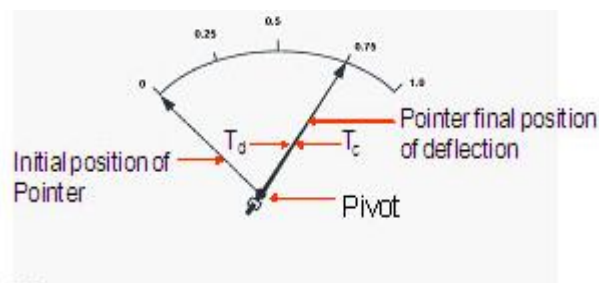

Fig 2.5 The Action of Controlling Torque

The controlling torque is provided in the following ways.

1. Spring control
2. Gravity control

### a. Spring Control

In this, the spindle of the moving system rests on two pivots. A helical hair spring usually made of phosphor bronze is attached to the moving system in such a way that its one end (inner side) is fixed to the moving system, while the outer end to a rigid body. The stress in the spring exerts a torque on the moving mechanism opposite to the motion of the moving mechanism. This torque is proportional to the angle of deflection.

Initially when the pointer is at zero deflected position, the controlling torque is zero as there exists no stress in the helical spring. At the final deflected position, torque produced by the spring would become equal and opposite to deflecting torque.

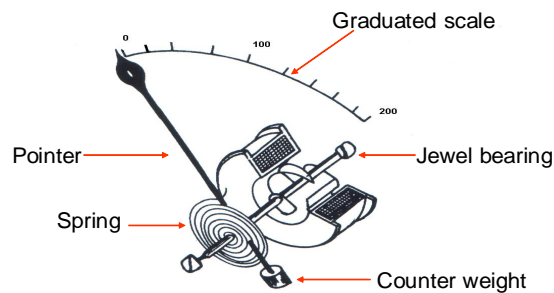

**Fig. 2.6 The Action of Spring Control Torque**

### b. Gravity Control

In this method, a small weight is attached to the moving system in such a way that it gets activated at the time of deflection and produces a controlling torque in proportion to the deflection. The magnitude of the controlling torque can be varied by adjusting the position of the controlling weight upon the arm.

The above figure shows the arrangements and corresponding positions of the control arm for zero deflection. In the zero deflected position of the pointer, the control weight stands vertical due to which the force due to gravity directly acts on the pointer and no torque exists on the pointer. As the deflection takes place the control arm also shifts from vertical position with an angle to vertical (position) to that of deflection.

*But the disadvantages of gravity control are*

- (i) It gives cramped scale
- (ii) The instrument has to be kept vertical

However gravity control has the following advantages

- (i) It is cheap
- (ii) It is unaffected by temperature
- (iii) It is not subjected to fatigue or deterioration with time

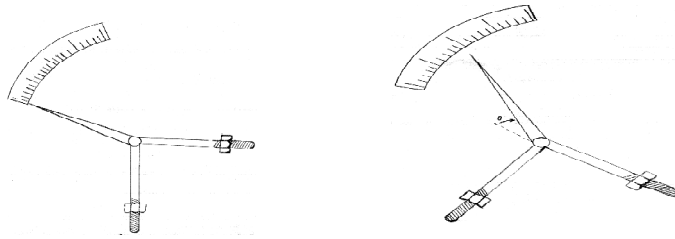

Fig. 2.7 Gravity Control Torque

### 2.4.3 Damping Torque

In the indicating instruments, the pointer will oscillate about its deflected position before coming to rest due to inertia. To bring the moving part to rest at the quickest possible time at the deflected position, a force is used which is called damping force. It operates on the moving system to bring it to rest at the quickest possible time. The instrument provided with a damping system is known as *dead beat* type instrument. Different devices are used to provide suitable damping.

The various methods adopted for damping are.,

- a) Air friction damping
- b) Fluid friction damping
- c) Eddy current damping

The system used varies with the type of instrument. Each method is discussed in the succeeding paragraphs.

#### a. Air friction damping

Two methods are employed in air friction damping. The first method uses a light aluminium piston attached to the moving system as shown in figure. The piston moves inside the air chamber along with the pointer.

As the piston slides in the chamber, the air inside the closed space is compressed and the pressure so developed opposes the motion of the piston.

The only care that must be taken so that the piston is not bent or the piston does not touch the walls of the chamber. It would lead to serious errors in reading.

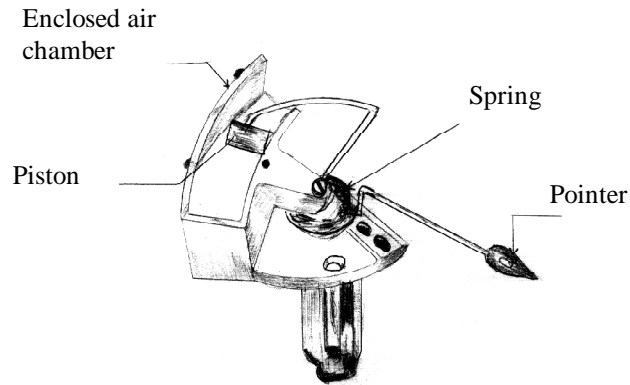

**Fig. 2. 8 Air Friction Damping with Piston air chamber**

The second method employs a vane mounted on the spindle of the moving system.

It is made of thin sheet of aluminium and moves in a closed sector shaped box . This method is more advantageous. Since the vane rotate along with the spindle in the sector box. Care has to be taken at the time of mounting to see that the vane is free inside the sector box.

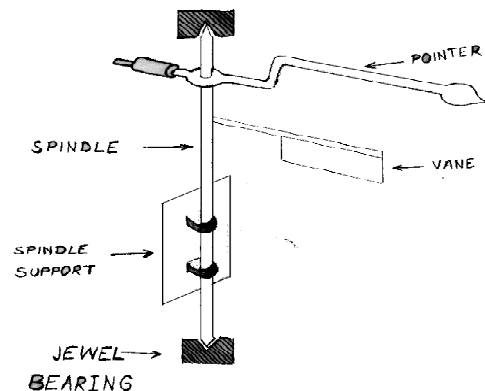

**Fig. 2.9 Air Friction Damping with aluminium vane**

### **b. Fluid friction damping**

In this method of damping, a light vane is attached to the spindle which is dipped in a pot of high viscus damping oil. The motion of the moving system is always opposed by the friction of the damping oil. The damping force created increases with the increase in velocity of the vane. There exists no damping force when the vane is stationery.



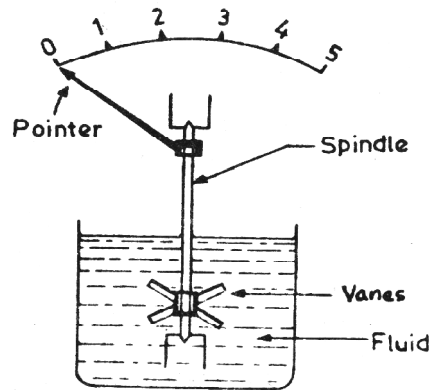

Fig. 2. 10 Fluid Friction Damping

### c. Eddy Current Damping

In this system, a circular disc (copper or aluminium) disc is mounted on the spindle and it is made to move in a magnetic field along with the spindle. The disc cuts the magnetic lines of force of the magnet and eddy currents will be induced in it. The induced eddy currents opposes the motion and thus a damping force is developed in the instrument.

There is an another type of eddy current damping system, which is used in permanent magnet moving coil instruments. The coil is wound on this aluminium frame, in which eddy currents are produced when the coil moves in the field of the permanent magnet.

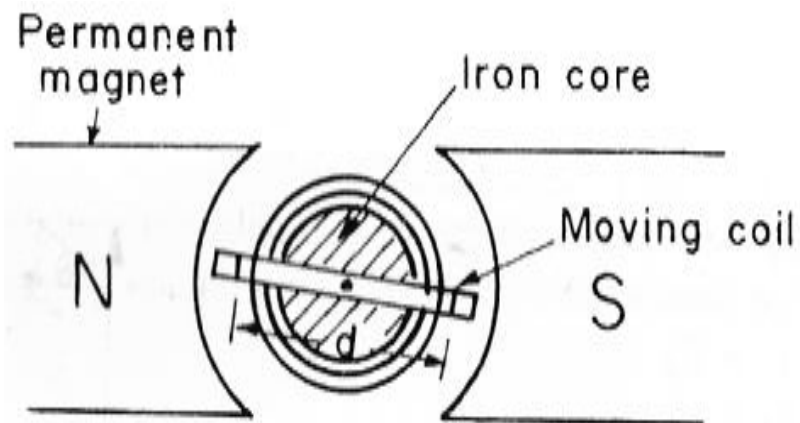

Fig 2.11 Eddy Current Damping By Thin Aluminium Frame

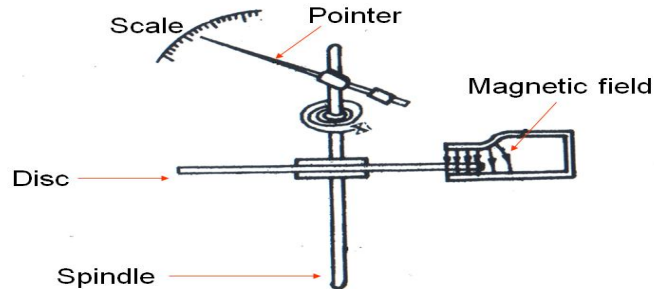

Fig 2.12 Eddy Current Damping By Thin Aluminium Disc

## 2.5 Ammeter and Voltmeter

Ammeter is an instrument in which torque is produced by the current to be measured. It has low resistance coil, so that it can be connected in series to the circuit without any appreciable voltage drop in it. Whereas a voltmeter has a high resistance coil and it carries a current which is proportional to voltage across the circuit to be measured and the torque is produced due to this current.

The only difference between the two (Ammeter and voltmeter) is in the magnitude of the current and method of connecting in circuit. Ammeter is connected in series with circuit and Voltmeter is connected in parallel with the circuit.

Ammeter and voltmeter are grouped together because there is no essential difference in the principle between them.

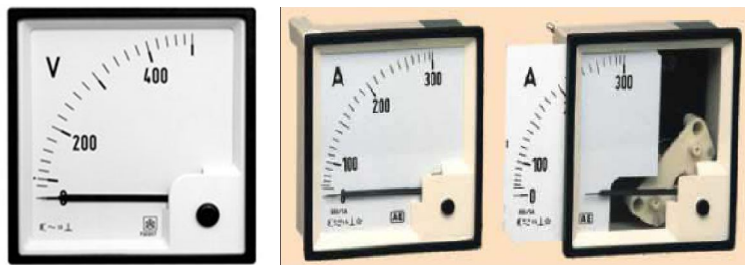

Fig 2.13 Ammeter

Voltmeter

Ammeter and voltmeters are classified as follows.

- a) Moving coil instrument
  - (i) Permanent magnetic type
  - (ii) Electro dynamic or dynamic type
- b) Moving iron instrument
  - (i) Attraction type
  - (ii) Repulsion type
- c) Hot wire type
- d) Induction type
  - (i) Split phase winding
  - (ii) Shaded pole type
- e) Electrostatic type

## 2.6 Permanent Magnet Type Moving Coil Instrument

This instrument is also called moving coil instrument. It is more accurate, sensitive and has uniform scale. It is most commonly used for DC measurements.

### Principle

It works on the principle of electro dynamic effect or principle of DC motor. It states that, whenever a current carrying conductor is placed in a magnetic field, it experiences some mechanical force and moves in a particular direction.

### Construction

It consists of a U- shaped permanent magnet. This powerful magnet is made of alnico. A rectangle coil of many turns wound on light aluminium frame is kept inside the pole pieces as shown in the figure. This frame is supported by delicate bearing and to which a light pointer is attached. The aluminium frame provides support for the coil and also acts as damping device by eddy current.

### Working

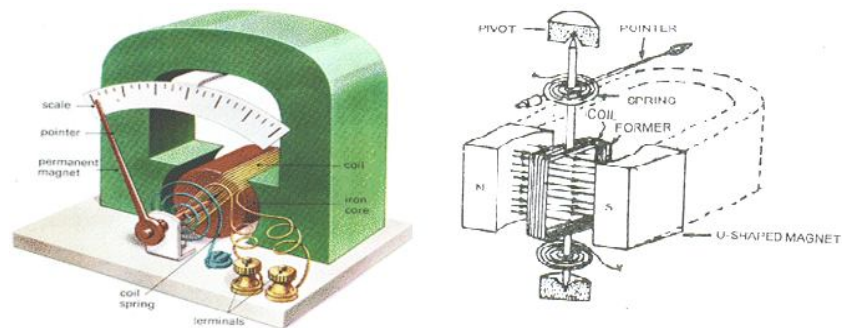

Fig 2.14 Construction of Permanent Magnet Moving Coil instrument

When this instrument is connected in a circuit, the current is passed through the coil. As the coil is kept in magnetic field, it experiences a torque and deflected due to electrodynamic effect. The deflecting torque is proportional to the quantity of electricity or current which is under measurement.

### **Controlling Torque**

Control of the coil moment is by spring control method, by using two phosphor bronze hair spring-one above and one below. They additionally serves the purpose of passing of current *in* and *out* the coil.

### **Damping torque**

Eddy current damping is provided by the Aluminum frame, on which the copper coil was made. When the coil rotates in the magnetic field, the Aluminium frame also moves along with the coil. Hence eddy currents will produce in the frame and there by damping torque is developed.

### **Applications**

This type of instruments are more sensitive, accurate and has uniform scale. They can be used for measurement of DC voltages and currents.

---

## **2.7 Moving Iron Instruments**

This type of instruments work on the principles of magnetism i.e., attraction or repulsion between two magnetized iron pieces. There are two types of moving iron instruments.

They are

- 1) Attraction type moving iron instrument
- 2) Repulsion type moving iron instrument

### **2.7.1 Moving Iron Instrument -Attraction type**

#### **Principle**

Moving iron instrument works on the principle of magnetism. i.e., A magnet attracts the iron piece or Unlike magnetic poles attract each other.

#### **Construction and working**

It consists of a fixed air core coil made by insulated copper wire and an oval shaped soft iron disc fitted on a spindle. The spindle is pivoted between two jewelled bearings near to the coil. A pointer is attached to the spindle, which moves on a pre-calibrated nonuniform scale.

The deflecting torque is produced by current passing through the coil (magnetic effect of electric current). The controlling torque is provided by either gravity or spring control method and damping is by air friction method.

When the instrument is connected in a circuit, the current passing through the coil will produce a magnetic field and *attracts the iron disc* inside. Along with the disc, spindle also rotates and causes the pointer to move on the scale. The deflection of the pointer is depends on the magnitude of current passing through the coil.

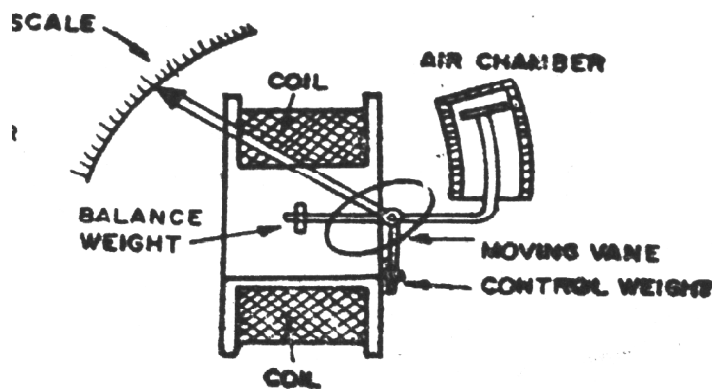

Fig. 2.15 Attraction type Moving Iron Instrument

If the current in the coil changes its direction, the polarity of induced magnetic field also changes. In that case also, the coil *attracts the iron disc* inside the coil by inducing opposite polarity in it. Hence these type of instruments can be used for AC and DC.

The attraction force is directly proportional to square of current ( $F \propto I^2$ ). Therefore, the scale is crowded/cramped at starting and finishing ends.

### Applications

The Moving Iron attraction type instrument can be used for AC and DC measurements (Voltmeter and Ammeter)

### 2.7.2 Moving Iron Instrument - Repulsion Type

#### Principle

Moving Iron Instrument works on the principles of magnetism. i.e., the like magnetic poles repel each other or when the same type of magnetic materials are placed in a magnetic field they will magnetised uniformly and hence the repulsion is takes place between them.

### Construction and Working

In this, a fixed coil is used as an electro magnet and two soft iron rods/strips are arranged inside the coil as shown in figure. The movable strip/rod carries a pointer that moves over the calibrated scale.

The deflecting torque is by magnetic effect of electric current. The controlling torque is by springs or gravity system and damping is by air friction system.

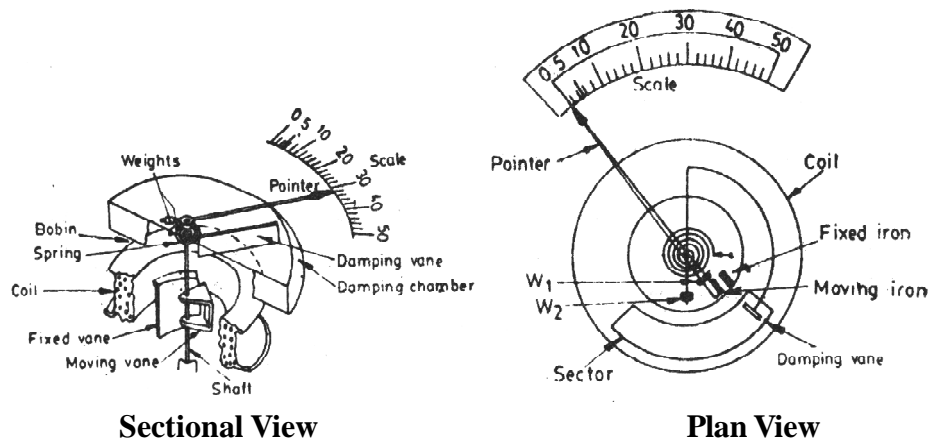

**Fig. 2.16 Repulsion type Moving Iron Instrument**

When the instrument is connected in a circuit the current passed through the fixed coil and sets up a magnetic field which magnetises the two rods of similar polarity. Then a repulsive force will develop between them and spindle moved.

Then the pointer attached to the spindle moves on the scale showing the value of electrical quantity. The force of repulsion is approximately proportional to the square of the current passing through the coil and hence the scale is crowded at ends.

Whatever the direction of current in the coil, the polarity induced on the *iron strips* is same. Hence always there will be a *repulsive force*. Therefore it can be used for AC and DC measurements.

### Applications

The Moving Iron repulsion type instrument can be used for AC and DC measurements (Voltmeter and Ammeter)

## 2.8 Advantage and Disadvantages of Moving Iron Instruments

1. These instruments can be used both on A.C and D.C system.
2. These instruments are robust and free from maintenance
3. It possesses high starting torque.
4. It can withstand momentary over loads.
5. It can give reasonable accuracy in the reading.
6. In this instrument the scale is nonuniform.
7. Power consumption is high at low voltage
8. The stiffness of the spring decreases with increase in temperature.
9. Hysteresis and stray magnetic field causes errors in the reading.
10. Change in frequency of operation causes serious error.

## 2.9 Differences between the Moving Coil and Moving Iron Instruments

	Moving coil instruments		Moving Iron instruments
1.	It works on the principle of DC motor	1.	It works on the principles of magnetism.
2.	Deflection torque is proportional to current	2.	Deflection torque is proportional to square of current
3.	Damping is provided by eddy current	3.	Damping is provided by air damping
4.	Spring controlled instruments	4.	Gravity controlled instruments.
5.	Controlling torque is proportional to angle of deflection	5.	Controlling torque is proportional to $\sin \theta$
6.	Scale is uniform	6.	Non uniform scale.
7.	Delicate, sensitive and accurate.	7.	Robust, reliable accurate.
8.	Costly.	8.	Cheap.
9.	Low power consumption	9.	high power consumption than moving coil.
10.	It is used only in D.C. Circuits.	10.	It is used both in A.C. and D.C. Circuits.
11.	Can be used as volt meter, Ammeter, Galvanometer, ohmmeter	11.	Can be used as Ammeter, Voltmeter and Watt meter.

## 2.10 Extension of Range of MC and MI Instruments - Need of Shunts and Multiplier

Normally all the measuring instruments are designed for a (current) range between few micro amps to milli amps for full scale deflection. If the instrument has to be used for higher ranges of current and voltage certain amount of resistance is added in series or parallel to coil.

If you observe an ammeter a small wire is connected to the coil and a high value resistor is connected in the case of voltmeter. Some times we can see these additional parts outside of the instrument.

Usually manganin and *nichrome* is used as resistance material. It is wound on an insulated former and leads are soldered to two large copper blocks. To increase the dissipating surface manganin is employed in the form of thin strips.

### a. Shunt ( $R_{sh}$ )

Shunt is a small amount of resistance connected in parallel with ammeter. It is used to extend the range of Ammeter.

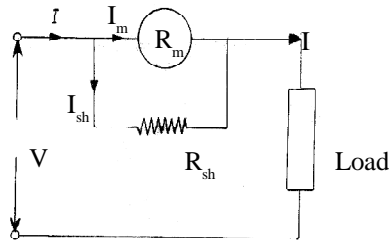

2.17 Shunt - extension of ammeter

Let the current for full scale deflection (FSD) of Ammeter is  $= I_m$ , Amps.

The meter resistance of coil resistance  $R_m, \Omega$

Load current or new range -  $I$ , Amps

Current in shunt resistance,  $I_{sh}$  Amps

Shunt resistance  $= R_{sh}$ , ohms.

$$\text{Shunt resistance } R_{sh} = \frac{I_m R_m}{I - I_m} \text{ ohms}$$

### b. Multiplier ( $R_{se}$ )

A Multiplier is a large amount of resistance connected in series with voltmeter. It is used to extend the range (measuring capacity) of voltmeter.



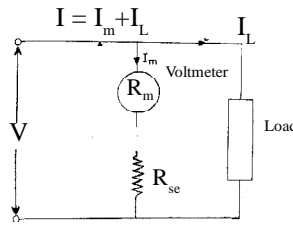

**Fig. 2.18 Multiplier - extension of Voltmeter**

Let the full scale deflection (FSD) voltage =  $V$ , Volts

The meter resistance =  $R_m$ , ohms,

Load voltage or new range =  $V$ , Volts

$$\text{The multiplier resistance } R_{sc} = \left( \frac{V - V_m}{V_m} \right) \cdot R_m \text{ ohms}$$

### 2.11 Measurement of Power - Watt-meters

Till now we have studied about measurement of current and voltage (ac or dc) by Ammeter and Voltmeter. Now we will learn about measurement of Electric Power by Wattmeter.

Wattmeter measures the electric power being consumed in the circuit/ equipment where it is connected. Small wattmeters measures power in watts where as the wattmeters in electric substations and power stations measures the power in kilo watts(Kw) and mega watts (Mw). Wattmeters mainly are following types

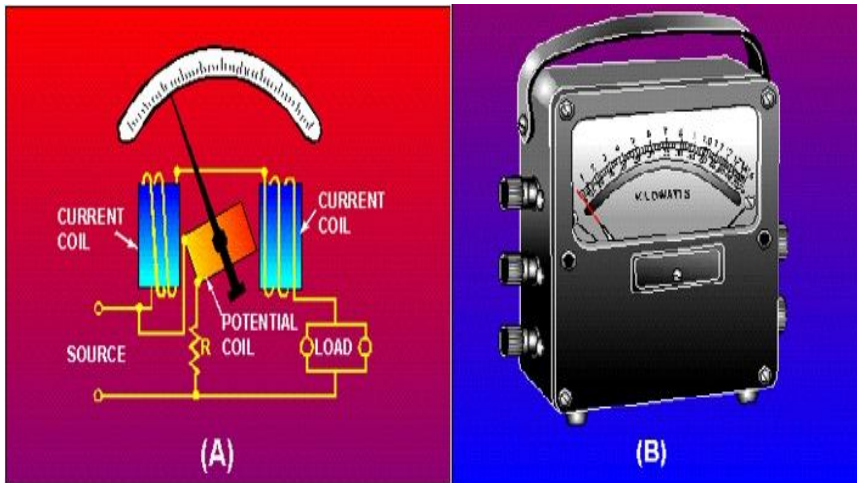

**Fig 2.19 Wattmeter**

### 2.11.1 Dynamometer Type Instruments

Electro dynamometer type instrument is also a moving coil instrument and can be used for AC and DC measurements. With this we can measure Current, Voltage and Power. But mainly it is used as wattmeter. Its scale is uniform when this instrument is used as wattmeter.

#### Principle

The dynamometer type instrument works on the principle of Electrodynamics effect of electric current (Principle of Motor). It states that “when a current carrying conductor is placed in a magnetic field, it experiences a force and moves away from the magnetic field”.

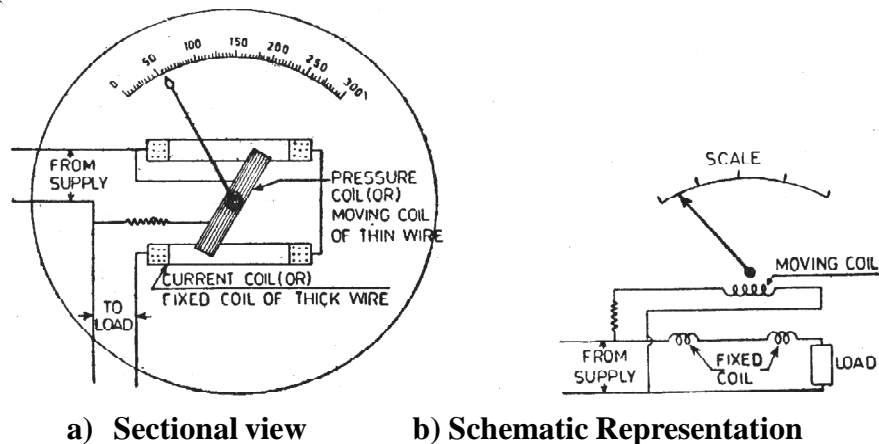

Fig. 2.20 Dynamometer type instrument

#### Construction

The instrument consists of two fixed coils and a movable coil. The fixed coils are made of a few turns of thick copper wire and called *current coil*. The movable coil of fine copper wire and made on thin aluminium frame and called *pressure coil*. It is placed on the spindle which was pivoted on two bearings. A hair spring is attached to spindle to provide controlling torque. Damping is provided by eddy currents induced in aluminium frame. The other arrangements are as shown in figure.

#### Working

When the instrument is connected in a circuit, the current passes through the both coils. The flux produced by current coil is proportional to load current and the current through moving coil is proportional to the voltage across the load. Because of these two types of fluxes, different magnetic fields were developed. Hence the moving coil experiences a force and moves (deflects).

The deflecting torque is proportional to the product of voltage and current in the two coils.

### Applications

The Dynamometer type instrument can be used as Voltmeter, Ammeter and Wattmeter.

#### 2.11.2 Induction type Instruments

The induction type of instruments has wide applications as wattmeter and energy meter but can also be used as ammeter and voltmeter. The deflecting torque is produced by the eddy currents induced in an light aluminium or copper disc or drum by revolving flux created by electromagnets. It has a wide scale spread over  $300^\circ$

Induction type instruments are used only for A.C. Measurements.

#### Induction Wattmeter

##### Principle

The Principle of induction wattmeters is the same as that of induction ammeter. The operation of all induction type instrument depends upon the production of torque due to the reaction between the flux ( $\phi$ ) and the eddy current in a metal disc due to other flux.

##### Construction and working

The wattmeter has two laminated electromagnets, one of which is excited by the current in the main circuit and called a series magnet. The other is excited by current which is proportional to the voltage of the circuit and called shunt magnet.

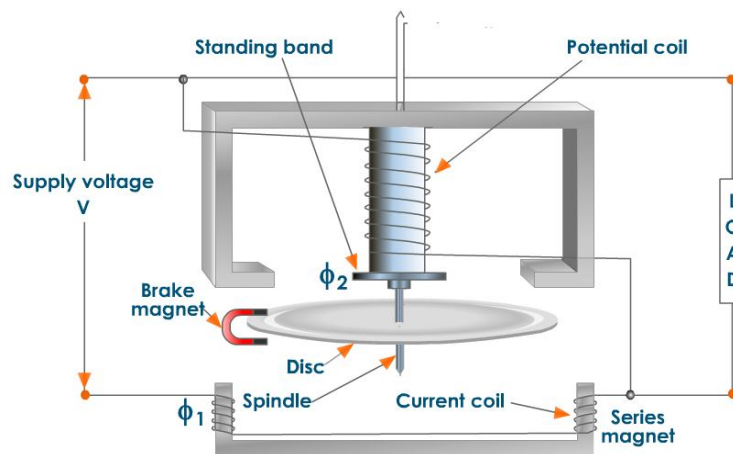

Fig 2.21 Induction type watt-meter

A thin aluminum disc is so mounted that it cuts the flux of both magnets. Hence two eddy currents are produced in the disc, and torque is produced in the disc. The deflection torque is produced due to the interaction of these eddy currents and inducing flux. Two or three copper rings are fitted on the central limb of the shunt magnet and can be also adjusted to make the resultant flux in the shunt magnet lag behind the applied voltage by  $90^\circ$ .

Induction wattmeter shown above is spring-controlled. The spring being fitted to the spindle of the moving system which also carries the pointer. The scale is uniformly even and extends over  $300^\circ$ .

Currents up to 100A can be handled by such wattmeter directly. But for currents greater than this value they are used in conjunction with current transformer. The pressure coil is purposely made as much inductive as possible order that the flux through it should lag behind the voltage by  $90^\circ$ .

### **Advantages and limitation of Induction Wattmeter**

These wattmeters possess the advantages of fairly long scale extending over  $300^\circ$ . They are free from the effects of stray fields, and have good damping. They are practically free from frequency errors. However they are subjected to (sometimes) serious temperature errors, because the main effect of temperature is on the resistance of the eddy current paths.

### **Key Concepts**

1. Working principles of indicating instruments
2. Ammeter, Voltmeter, Wattmeter

### **Activity**

1. Identify the main parts of ammeter, voltmeter, wattmeter
2. Connecting the above instruments in a circuit or to lamp/heater/any load and note the observations/readings.

### **Short Answer Type Questions**

1. What is indicating instrument?
2. List the main parts of indicating instrument.
3. Write the applications of Integrating instruments and Recording instruments?
4. What are the effects of current used in the measuring instruments?
5. Name different types of Moving coil and Moving iron instruments?

6. Define shunt and multiplier.
7. Define controlling torque. How it is arranged in instruments?
8. What are the advantages of Moving Iron instruments?
9. Name different types of wattmeters and write their applications.

---

### **Long Answer Type Questions**

1. Draw the construction and explain the working of PMMC.
2. Show the parts of Moving Iron attraction type instrument and explain its working with neat sketch.
3. Write the comparison between moving coil and moving iron instruments
4. Draw a neat sketch of dynamometer type wattmeter and explain its working.
5. What is induction type instrument? Explain the construction and working of Induction type wattmeter.

---

### **On the Job Training/Project Oriented Questions**

1. Connecting the Voltmeter Ammeter and Wattmeter in a circuit or to a lamp /heater / any load and note the observations/readings.
2. Observe the current in different motors/appliances while they are running
3. Note the power rating of various loads in OJT centre.
4. Note the current, power rating of electric iron, washing machine, refrigerator and electric stove.

## UNIT

## 3

**Integrating Instruments****Learning Objectives**

- Definition and purpose of integrating type instruments
- Development of present energy meter
- 1-ph, 3-ph energy meter construction, working and connections.

**3.1 Integrating Instruments**

Integrating instrument are electrical measuring instruments, which measures the electrical quantity and sum up with previous value and provides a cumulative result of electrical quantity under measurement.

Eg: House hold energy meter

The best example for integrating instrument is energy meter. From the date of installing/fixing the meter in a house/electrical installation, it keep on measures the enerctrical energy and provides the cumulative result for the total period.

**3.2 Energy meter**

Integrating type energy meter is an indicating and recording type instrument. It provides a cumulative value of electrical quantity. It contains a set of dials, pointer, scale or suitable indicator and a recording mechanism. It indicates the value of the quantity under measurement sum up with previous readings.

They were two types namely

1. Watt-hour type energy meter
2. Ampere-hour type energy meter.

*Example:* Induction type energy meter,

Digital energy meter,

Ampere-hour meter etc.,

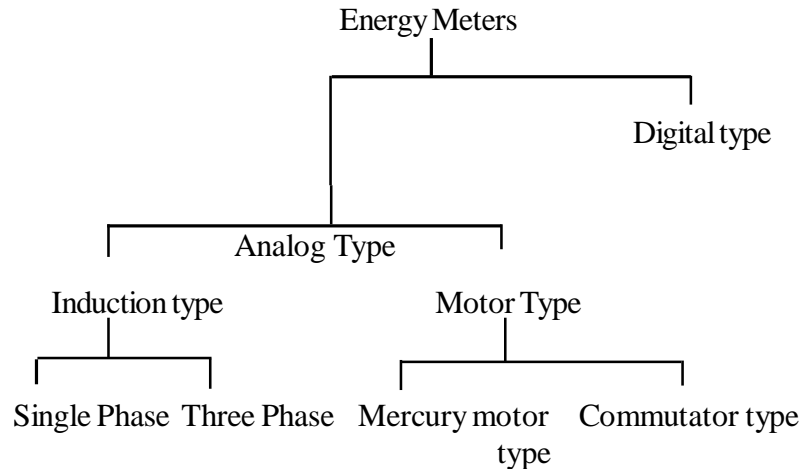

**Fig: 3.1 Standard Energy Meters**

### **Energy Meter- Classification**

Energy meters are Integrating Instruments, used to measure the quantity of electric energy supplied to a circuit in a given time.

They indicate the value of quantity of electricity at the time of measurement, and keep a cumulative record of previous values. Energy meters are also called as watt-hour meters. They measure the energy consumed in Kwh. (Kilo-watt-hour and 1 Kwh = 1 Unit)



The Induction type energy meters are used in a.c. circuits where as motor types meters are suitable for d.c. and a.c. circuit measurements. In this lesson, we focus our attention on Induction type energy meters.

### 3.3 Basic Elements of Induction type Energy Meter

An energy meter, similar to indicating instrument has following three important elements.

- i) Operating System
- ii) Braking System
- iii) Recording System

(i) *An operating system* which produces an operating torque proportional to the current or power in the circuit and which causes the rotation of the rotating system.

(ii) *A retarding or braking device* usually a permanent magnet which produces a braking torque in proportional and opposite to the speed of rotation. It stops the moving system/disc immediately when the meter was disconnected from the supply.

(iii) *A registering or recording mechanism* form the revolutions of the rotating system. Usually, it consists of a train of wheel driven by the spindle of rotating system. Through wheel arrangement. All these wheels are attached in such a way that if one wheel completes one revolution, the other moves only *one tenth* of a revolution.



### 3.4 Single Phase (1- $\phi$ ) Induction Type Energy Meter

#### Principle

The single phase induction type energy meter works on the principle of electro magnetic induction. A rotating magnetic field is developed due to interaction of current in pressure coil and current coil with aluminium disc placed near coils.

#### Construction and Working

The figure shows essential parts of single phase induction meter. It consists of a pressure coil made of thin copper wire of many turns (also called shunt magnet); a current coil made of thick copper wire of one or two turns (also called series magnet), an aluminium disc mounted on spindle and placed between two jeweled bearings and a recording mechanism consists of worm and wheel through which the rotation of spindle is recorded on cyclometer.

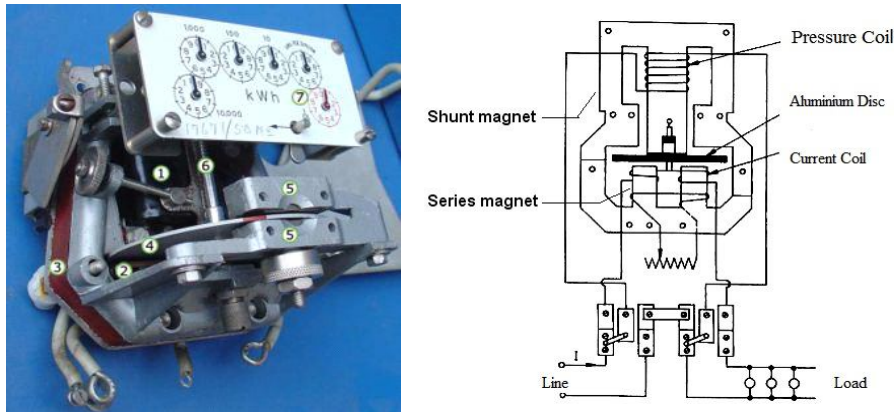

**Fig. 3.2 Constructional Details of Single Phase Energy meter**

A braking magnet is arranged on a disc to control its movement and to stop the movement under no load. It produces a damping torque/force. Here eddy current system of damping is used. A phase difference of  $90^\circ$  is set between current coil and pressure coil with the help of copper shaded rings.

The two field fluxes produced by the two coils act on aluminium disc induce eddy currents and hence the disc rotates due to the interaction of the two fluxes developed. The speed of disc is proportional to the energy consumed/power consumed by the load.

The number of revolutions completed by the disc for one 'Kwh' is called meter constant. Usually it is printed on name plate of meter.

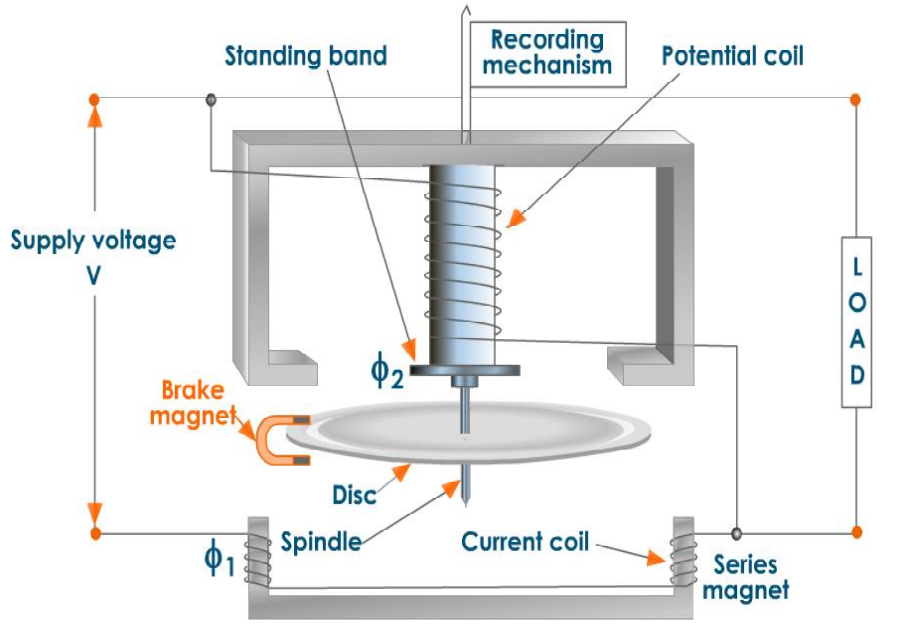

Fig 3.4 Internal parts of Energy meter

### 3.5 Errors in 1- $\phi$ Induction type energy meter

#### (1) Phase error or Power factor error

This error is due to improper phase difference between flux and voltage due to shunt coil. With this, the disc rotates faster at low p.f. loads. It is corrected by adjusting the position of the shading rings.

#### (2) Speed error

Some times the speed of disc is not proportion for non-inductive loads. This is due to incorrect adjustment of braking magnet. This can be eliminated by repositioning the brake magnet.

#### (3) Friction Compensation or friction error

In many cases an unwanted braking torque on disc will developed due to frictional forces at disc and register mechanism. This causes for creeping error. This can be adjusted by repositioning the shaded rings on central limb/shunt magnet.

#### (4) Creeping Error

Some times energy meter runs slowly, even at no load condition. This phenomenon is said to be creeping. This may occur due to over friction compensation, stray magnetic field or mechanical vibrations. This can be prevented by proper adjustment of friction compensation. Usually two small holes are cut near the circumference of the aluminium disc. Sometimes a small piece of iron wire is attached to the edge of the disc which when attracted by braking magnet.

#### (5) Temperature error

The error due to temperature in meter reading is very less. An increase in temperature results in increased resistance to the eddy current path reducing the driving torque and braking torque. It also increase the resistance of the shunt coil causing smaller current to flow, due to which the driving torque is reduced. At higher temperatures the flux from braking magnet is also less. The net result is to neutralize each others effect and error caused due to temperature is not appreciable.

#### (6) Frequency effect

Increase in frequency rises the impedance of the coils with the result less current flows through them. The torque produced is also proportionately reduced.

Hence the meter has to be adjusted at fixed frequency to obtain minimum error.

### 3.6 Polyphase Induction Type Energy Meter

Polyphase energy meters are obtained by combining two or more single phase energy meters. Two discs are mounted on the same common spindle and each disc has its own braking magnet. The common spindle drives a single gear train. Each unit is provided with its own shading rings. The working is similar to single phase induction type energy meter.

### 3.7 Three Phase ( $3\phi$ ) Energy Meters

The three phase energy meters works on the same principle as single phase energy meter. The energy in the three phase circuit can be measured either by two separate single phase energy meters or three separate energy meters or single Three phase energy meter

These are also called polyphase energy meters. They were two types 1) 3-Phase, 3-wire AC Energy meter. 2) 3-Phase, 4-wire AC Energy meter.

### (1) 3-Phase, 3-wire A C Energy meter.

The three phase three wire energy meter works on the principle of measurement of power by two watt meter method. It consists of two separate pressure coils and two current coils. They produce a driving force on a common disc. But in some models, there may be two discs attached to a common spindle with one element at top and the other at bottom.



Fig 3.2 Three phase, Three wire energy meter

### (2) 3-Phase, 4-wire A C Energy meter.

This meter has three 1-Phase elements working on three discs fixed to the same spindle pivoted on a jewelled bottom bearing and a pin type top bearing.

The discs are arranged to revolve in the air gap of the two electro magnets one supplied with current coils and other to the voltage (potential coil) The flux due to the two electromagnets produces a rotating field.

The torque and so the speed of disc is proportional to the power. If we consider the time then the number of revolutions of the disc is proportional to the energy. For adjustment of power factor and friction, shading rings are provided. The damping is provided with permanent magnets. The spindle is geared by a chain of wheels to the counter which indicates the energy supplied through the meter.

The principle of this meter is same as of three wattmeter method measuring power, as shown in the figure, the power is  $W_1+W_2+W_3$



Fig 3.3 Three Phase, Four wire Energy meter.

### Key Concept

- Energy Meter

### Activity

1. Observe the energy meter reading in your house write in a note book daily.
2. Calculate the consumption of energy from basic principles and compare it with actual meter reading.

### Short Answer Type Questions

1. What is integrating instrument?
2. How the energy meters can be classified?

3. What are the main parts of energy meter?
4. What are the possible errors in energy meters?

---

**Long Answer Type Questions**

1. Draw the construction and explain briefly about single phase energy meter.

---

**On the Job Training/Project Oriented Questions**

1. Record the energy consumption at various time periods (i.e., morning, afternoon evening and night).
2. Learn energy saving tips and apply.

## Special Instruments

### Learning Objectives

- Necessity of Special instruments
- Construction, working, applications of powerfactor meter, frequency meter, synchroscope, meggar, tongue tester, multi-meter.

### 4.1 Introduction

In the field of electrical engineering, there are so many physical quantities which needs measurement. So far we have discussed about the measurement of fundamental electrical quantities like current, voltage, power and energy. Here we are focusing our attention towards measurement of various quantities like Power factor, frequency etc., and related measuring instruments. We will also learn about multimeter, tongue tester, clip-on meter.

### 4.2 Power Factor Meter

The power factor meter is used to measure the cosine value of phase angle between applied voltage and current in an AC circuit directly. The working principle is similar to dynamometer instrument. Hence it is also called as dynamometer type p.f. meter. It has no control device i.e., arrangement for controlling torque. There are two types.,

- (1) Single phase p.f. meter
- (2) Three phase p.f. meter.

### 4.2.1 Single Phase Dynamometer Type P.F. meter

#### Principle

Power factor meter is used to measure the Power Factor of a circuit/load. Dynamometer type Power Factor meter works on the principle of dynamometer. It states that, whenever a current carrying conductor is placed in a magnetic field, it experiences a force and moves away from the magnetic field.

#### Construction

The constructional details of Power factor meter is as shown in the figure. This instrument has a stationary coil which is divided into two sections  $F_1$  and  $F_2$  and two moving coils  $C_1$  and  $C_2$  which are rigidly attached to each other and mounted on the same spindle. The fixed coils are called current coils and the moving coils are pressure coils or voltage coils.

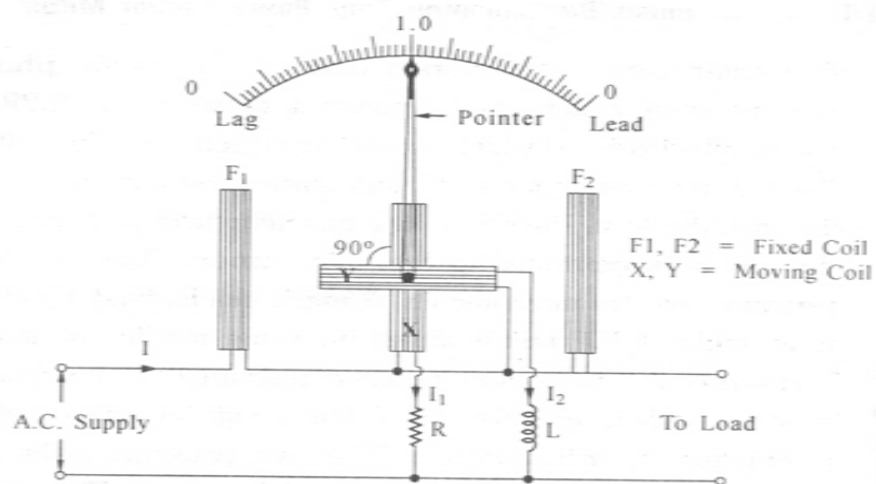

Fig 4.1 Single Phase Dynamometer Type P.F. meter

#### Working

When Power factor meter is connected in the circuit, a phase difference  $90^\circ$  is created between, the current  $I_1$  and  $I_2$  because of the resistance and inductance of the moving coils. Because of this current  $I_1$  and  $I_2$  flow in the moving coil. Hence the moving coil of the meter deflects, depending upon the power factor and shows the reading with the help of pointer.



### 4.2.2 Three Phase (3- $\phi$ ) Power Factor meter

The principle of operation of 3-phase Dynamometer type p.f. meter is similar to 1-phase Dynamometer type p.f. meter.

The three phase power factor meter consists of three fixed coils (current coils), which are placed  $120^\circ$  apart and connected in series with the load. The moving coils are arranged on the common spindle. A pointer is attached to the spindle. The moving coils are also called pressure coils or voltage coils and spaced  $120^\circ$  apart. The three ends are connected at one junction to form star point and the other ends are joined to the line through fixed resistances.

The basic constructional details are as shown in figure.

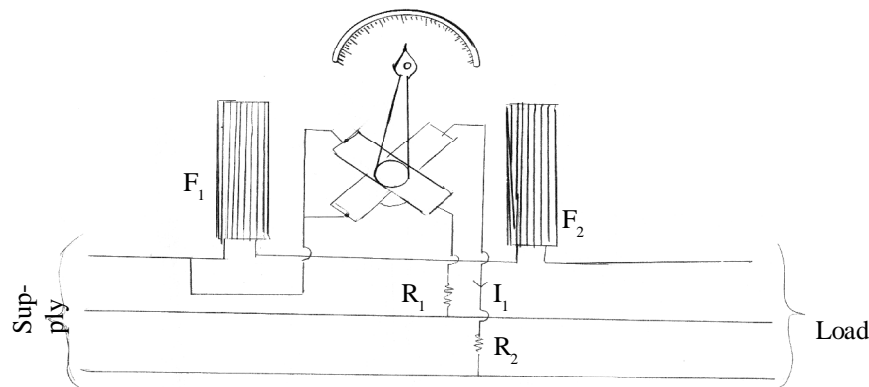

Fig 4.2 Three Phase Dynamometer Type P.F. meter

### 4.3 Frequency Meters

Frequency meters are often used to determine the number of cycles in a section of an Alternating quantity. There are several instruments designed to measure frequency in Hertz(Hz), Kilo Hertz (kHz) and so on., The frequency meters may be divided into four types, based on their fundamental working principles.

The frequency meters are following types,

1. Mechanical Resonance type or  
Vibrating reed type frequency meter
2. Weston type or Moving Iron type frequency meter
3. Electro-dynamic or moving coil type frequency meter

or dynamometer type frequency meter

#### 4. Electrical resonance type frequency meter

##### 4.3.1 Mechanical resonance type or vibrating reed type frequency meter

It works on the principle of mechanical resonance. It states that, if a vibrating body brought near to a flexible body, it also starts vibrate with same frequency as the vibrating body, if its natural frequency is equal to the frequency of vibrating body.

The vibrating reed type frequency meter consists of a laminated cored electro magnet. Four or five steel reeds of 4mm length and 0.5mm thickness with different natural frequency are mounted in one side of electromagnet. The free ends of the reeds are slightly bent and pointed as shown in figure.

When the alternating current, whose frequency is to be determined is passed through electromagnet, its magnetism alternates same frequency. Hence electromagnet exerts an attracting force on each reed. And it causes the reeds to vibrate based on the principle of mechanical resonance. But the reed, whose natural frequency is equal to frequency of alternating current will vibrate more and appears as a broad band and shows the value of frequency. This type of meter is very accurate and sensitive but its range is 48 to 52 Hz only.

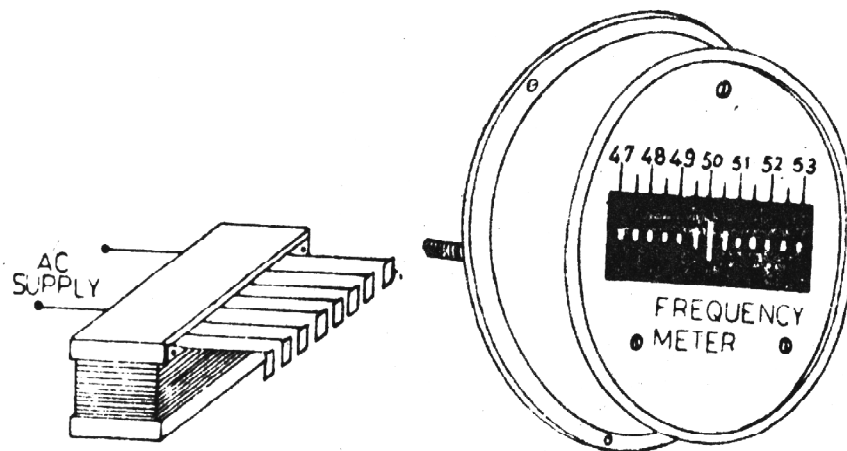

Fig 4.3 Vibrating reed type frequency meter.

### 4.3.2 Moving Iron Frequency Meter

#### Principle

The action of Moving Iron Frequency meter depends on the variation in current drawn by two parallel circuits. One inductive and the other non inductive when the frequency changes.

#### Construction

It consists of two sets of coil A and B placed with their magnetic axis at right angle to each other. A soft iron is placed at the centre of the coils group and a pivoted needle which carries a pointer moves over the graduated scale. In this air damping is provided without a control spring.

#### Working

On connecting the instrument across the supply, currents pass through two coils A and B and produce torques which are of opposing nature. When supply frequency is high, current through coil A is more whereas that through coil B is less due to increase in reactance offered by  $L_B$ . Hence magnetic field of coil A is stronger than that of B.

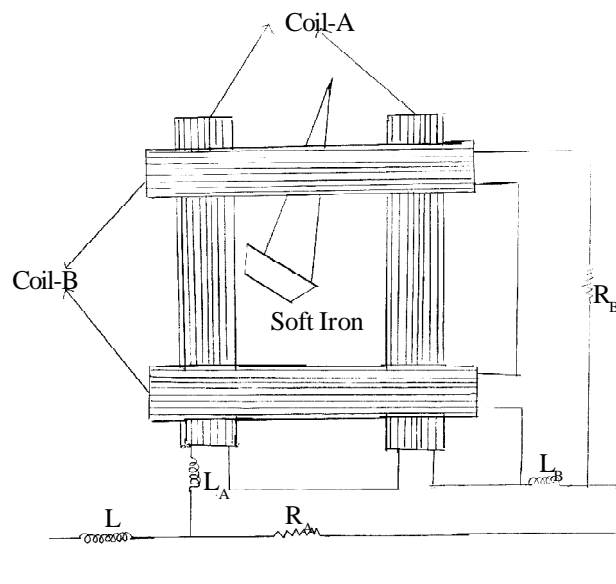

Fig 4.4 Moving Iron Frequency meter

The instrument can be designed over a broad (or) narrow range of frequencies determined by the parameters of the circuit.

#### 4.3.3 Moving Coil or Dynamometer type Frequency Meter

It is one type moving coil type meter and works on the principle of Electrodynamics. It consists of two moving coils placed perpendicular to each other between the poles of U-shaped magnet/bar magnet. A pointer is attached to the coils to show the frequency on scale. A bridge circuit, a resistor (R) and a capacitor (C) also connected.

When the instrument is connected in a circuit, opposing torques are produced by two coils. The pointer will be deflected in the direction of resultant torque and indicate the frequency of a.c. supply. This meter can be designed to measure frequency ranges of 40-60 Hz/1200-2000 Hz/8000 to 12000Hz by varying the values of R & C.

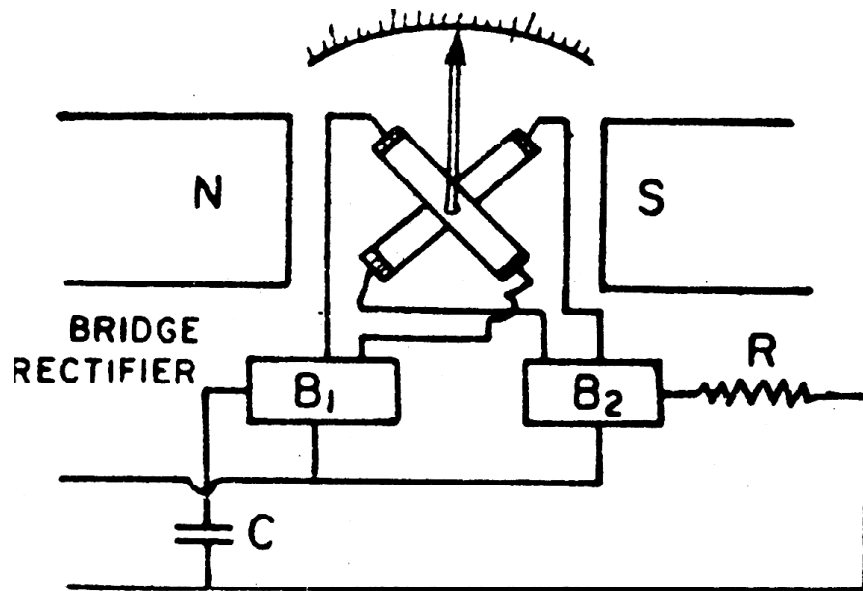

Fig 4.5 Dynamometer type Frequency meter

## 4.4 Synchrono Scope

For connecting an alternator with live alternators or to connect an running alternator to a live bus bars, Synchro scope is used. Generally we can see them in big power stations and big sub-stations. They are two types.

- (a) Weston synchrono scope
- (b) Moving iron synchrono scope.

### 4.4.1 Weston synchrono scope

The western type synchronoscope consists of a three limbed transformer. The winding of one outer limb was excited from one alternator and the other by incoming alternator. The central limb was connected with a lamp as shown in figure.

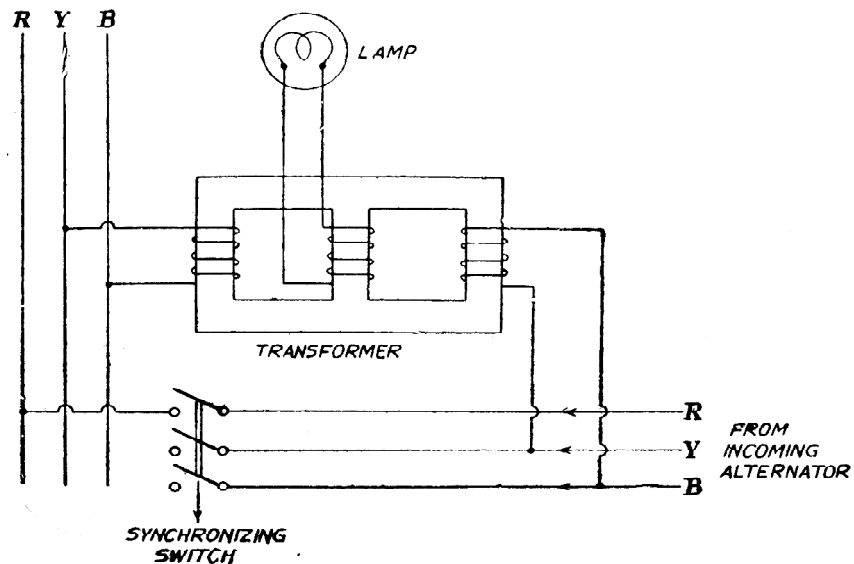

Fig 4.6 Weston synchrono scope

The resultant flux in the central limb is equal to the phasor sum of two alternators. If incoming voltages are 'inphase ( $0^\circ$ )', the two fluxes are additive nature and produces more emf in the central limb, causing the lamp to glow with

full brightness. When the two voltages are 'out of phase ( $180^\circ$ )', the lamp will not glow at all. If there is any frequency difference between two alternators, the lamp will flicker. After confirming the two voltages are 'in phase', the synchronizing switch is closed.

#### 4.4.2 Moving iron synchrono scope.

##### Construction

The construction of moving iron synchronoscope is similar to single phase moving iron power factor meter. It has two iron pieces mounted one above the other on a common spindle as shown in the figure. The fixed coil  $F_1$  and  $F_2$  is connected across the bus bar while the pressure coil connected across the terminals of the in coming alternator. In one of the pressure coils a non inductive resistance  $R$  is connected in series while in the other an inductive ( $L$ ) coil is connected in series.

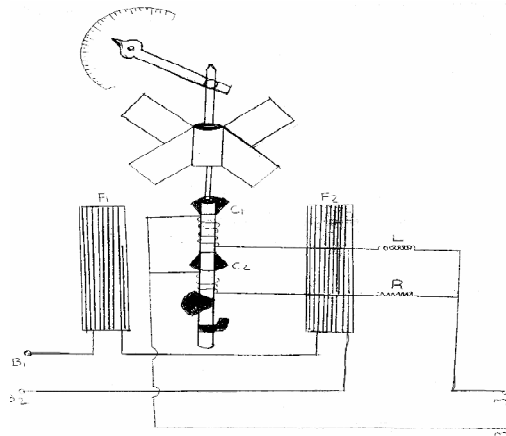

Fig 4.7 Moving iron synchrono scope.

##### Working

When the incoming frequency is equal to that of bus bar the synchrono scope works as a single phase power factor meter and so indicate the phase difference to that of bus bar. The spindle rotates continuously at a speed in revolutions per second equal to the difference of the frequencies of the two systems. The instrument has  $360^\circ$  scale and the displacement from the Zero position gives the difference in the phase between the two emf's. And when the pointer is stationary center zero is shows the synchronizing time.

### 4.5 Multimeter (AVO Meter)

A multimeter is a combined unit of Ampere meter, Voltmeter and Ohmmeter. It is used for measurement of AC/DC Voltage, Current and Resistance. It is also known as multi-tester or AVO meter.

A number of resistors, thin wire coils are connected inside the meter, so as to provide different ranges of amperes, volts and ohms. Fundamentally it is a Permanent Magnet Moving Coil Instrument. Hence a rectifier is also inserted in the circuit to facilitate AC measurements.

Normally a multimeter has following ranges,

D C Voltage 0-0.5/2.5/10/50/250/1000V

A C Voltage 0-2.5/10/50/250/500/1000V

Direct Current 0-50  $\mu$ A/2.5mA/25mA/250mA

Resistance 0-10 K $\Omega$ /10 M $\Omega$ .

A battery of 3V is put in AVO meter for measurement of resistance. The required electrical quantity with suitable range can be selected by a rotary switch or separate terminals depending on the design. The internal connections of a typical AVO meter are as shown in figure.

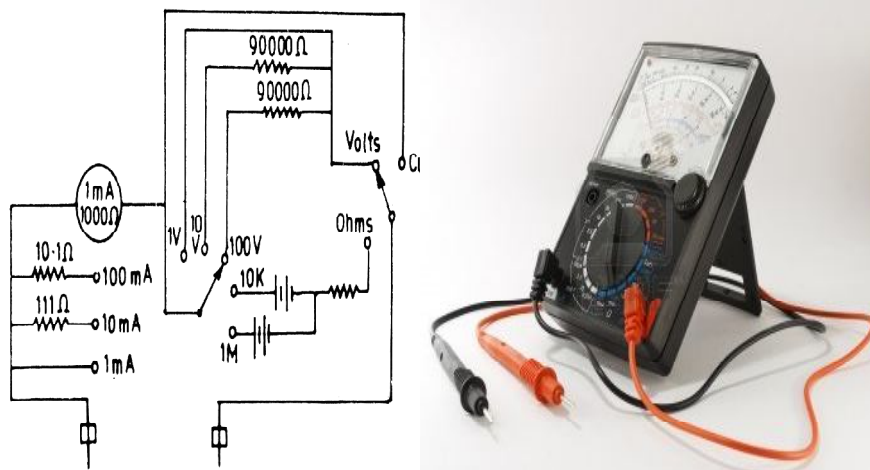

Fig. 4.8 Internal Connections and external view of Multimeter

#### 4.6 Tongue Tester or Cell Tester of High rate discharge cell Tester

Tongue tester is an instrument and used to check the charge condition and actual condition on high current discharge of a Lead acid battery/cell.

It consists of a wooden handle, two metal strips, a low resistance, a voltmeter and an indicator.

When the cell tester is put on the terminals of battery (not more that 10 seconds) a high current passed through resistance . Then the voltage should be 1.8V. If it is less, there may be a under charging, damage in plate or active material.

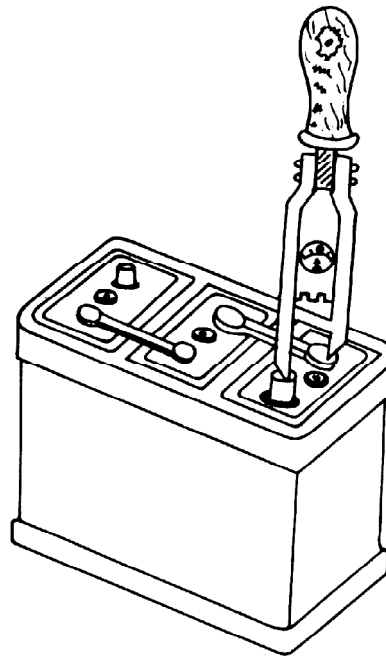

Fig 4.9 Tongue tester or Cell Tester

#### 4.7 Megger

Megger is a portable instrument used for testing the earth resistance, wiring and insulation resistance of a circuit or electrical machine or equipment.

The meggar has two main parts. One part is a hand driven D C Generator and the other is ohm meter or resistance measuring unit. The internal connections of Megger are shown in figure. It works on the principle of 'ratio meter type ohm meter'.



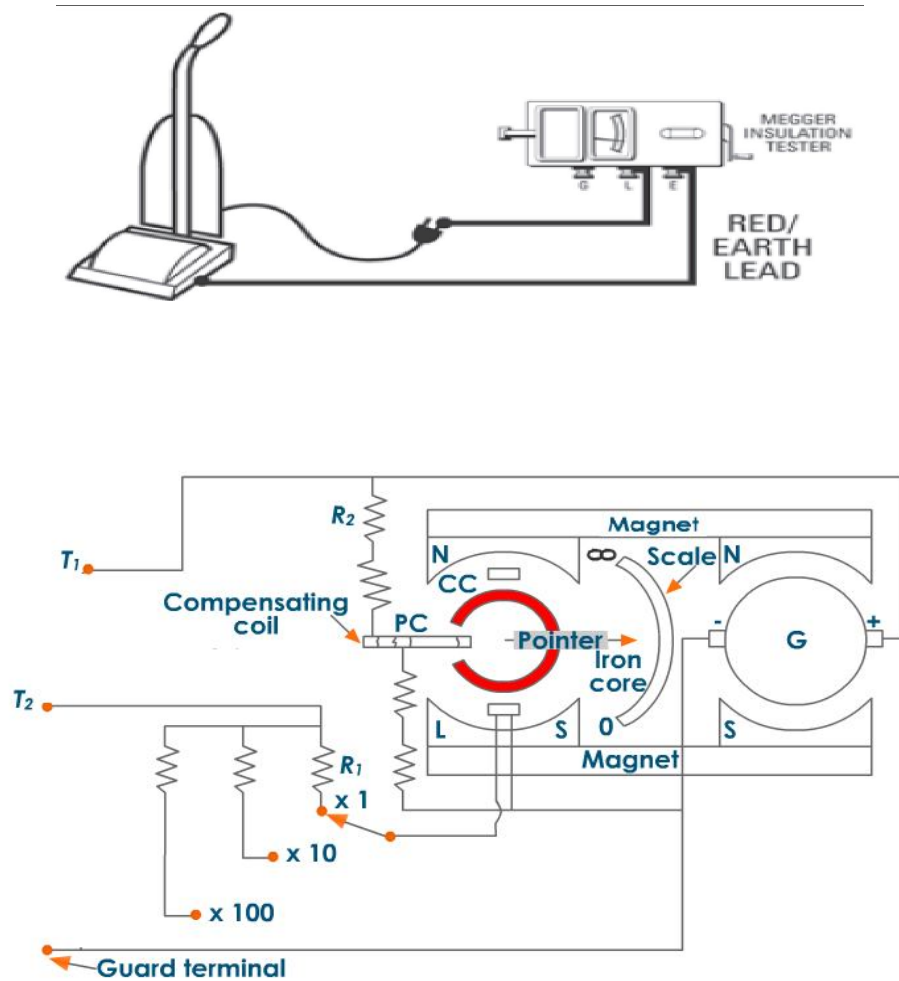

Fig 4.10 Internal details of Megger

The DC Generator produces emf, based on the principles of Faraday's laws of electromagnetic induction. In some instruments a rectified AC supply or a battery is used as source of power. The ohm meter contains a pair of permanent magnets. Between them, two coils (pressure coil and current coil) which are attached to the spindle are arranged. A pointer is also connected to the spindle.

When the Megger is connected in the circuit and on operation of DC Generator, the pointer shows directly the value of resistance on scale. The deflection of the pointer depends on resistance of circuit, current in coils, reaction with main field and resulting torque.

---

**Key Concepts**

To know the construction, working operation and application of social instruments like powerfactor meter, frequency meter, multimeter, megger etc

---

**Activity**

1. Calculate the power factor of a motor or any other RLC load and test of power factor
2. Improve the power factor by connecting a capacitor/VAR load
3. Practice the operation and usage of multimeter and megger
4. Collect information about frequency

---

**Short Answer Type Questions**

1. Write the uses of Frequency meter, synchronoscope, multimeter, pf meter and megger.
2. What is the working principle of vibrating reed frequency meter?

---

**Long Answer Type Questions**

1. Draw a neat sketch of single phase dynamometer type p.f. meter.
2. Explain the construction and working of vibrating reed type instrument.
3. How the weston synchronoscope is used to connect alternator to live bus bars.
4. Explain about multimeter and its operation.

---

**On the Job Training/Project Oriented Questions**

1. Observe the use of multimeter, megger, hydrometer and tongue tester in OJT site.

## An Introduction to Digital Instruments

### Learning Objectives

After studying this unit, the student will be able to understand

- Need and importance of digital instruments
- Construction, working, applications/uses of digital voltmeter, ammeter, tachometer and multi-meter.

### 5.1 Need of Digital Instruments

The permanent magnet moving coil instrument, moving iron instrument, dynamometer type instrument and other instruments described in earlier chapters were all analog instruments. They are cheap and simple in their operation. However they are not suitable for fast developing technology. Because, the reading can't be taken quickly and accurately. To overcome the drawbacks of analogue instruments, digital instruments are developed. They display the readings in digital form.

### 5.2 Advantages and disadvantages of Digital Instruments

The digital instruments can be made to much accuracies, easy and fast readable, better resolution and automatic polarity and zeroing. They consume very less power for their operation. There is no moving parts, hence greater portability and positioning can be possible.

The analogue instruments are simple in construction and with stand different types of atmospheres surroundings. It is not possible with digital instruments

because they are made from semiconducting materials. They need specialized atmosphere like controlled temperature, clean environment etc.,

### 5.3 Essentials of an Electronic / Digital / Instruments

As shown in the following block diagram, there may be three basic elements in an Digital / Electronic Instruments.

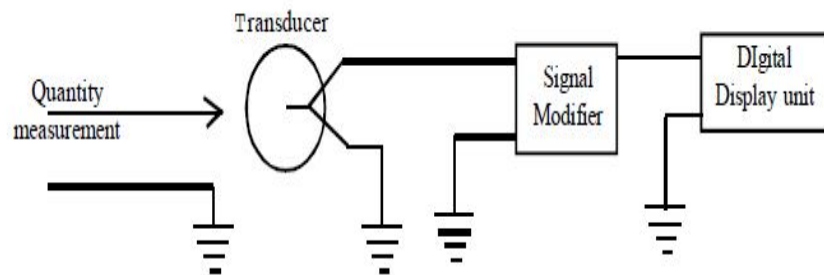

Fig. 5.1 Block diagram of Electronic / Digital Instruments

#### Transducer

The sending element is required only when measuring a non-electrical quantity (say temperature, pressure etc.,) Its function is to convert non-electrical physical quantity to electrical signal. If the quantity is electrical, it is not required.

#### Signal Modifier

It makes the incoming signal suitable for application to the measuring and indicating system.

#### Display Device

They indicate the value of the measured quantity in decimal digits in the digital instruments. It receives digital information and projects into decimal form through segmental display (LED or LCD), lucid sheets, grid illuminated dots., Nixie tubes etc.,

### 5.4 Digital frequency meter

The signal, where frequency is to be measured is converted into train of pulses, one pulse for each cycle of the signal. The number of pulses appearing in a definite time period is counted by an electronic counter. The number of appearing on the counter is direct value of frequency of the unknown signal.

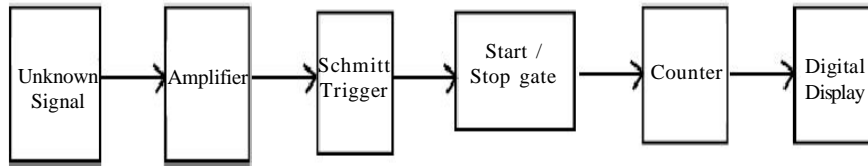

Fig. 5.2 Block diagram of Digital Frequency Meter

### 5.5 Digital Voltmeter - Ammeter - Ohm Meter

A Digital Voltmeter (DVM) measures and display the value of ac or dc voltages in decimal number system.

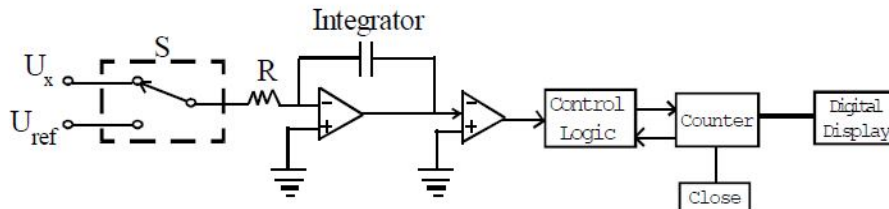

Fig. 5.3 Block Diagram of Digital Voltmeter - Ammeter - Ohm Meter

The above block diagram represents the dual slope technique type DVM. It consists of an op-amp as integrator, a level comparator, a basic clock, a set of decimal counters and a block of logic circuitry.

The unknown voltage is applied at  $U_x$  along with a known reference voltage  $U_{ref}$ . The magnitude of voltage is displayed on a digital display.

The same instrument can be used for ac measurements by introducing an ac to dc converter. To measure the current, it is passed through a standard resistor. The voltage appearing across the resistor is then measured with a voltmeter. The value of current can be known from the counters through the readout system.

The same instrument can be used as an Ohmmeter / for measurement of resistance. A fixed current is passed through the unknown resistance from an in-built power source. The voltage drop across the resistor is proportional to the resistance and is measured by the voltmeter. The number of counts appearing on the digital voltmeter is the resistance.

### 5.6 Digital Multi-meter (DMM)

Digital Multi-meter (DMM) is a single instrument and used to measure resistance current (ac/dc) voltage (ac/dc) over a wide ranges and the output value in digital form.

To measure current, it is passed through a calibrated shunt resistance. The voltage drops across it is measured and applied to the counter to provide readout by digital display.



Fig. 5.4 Digital Multimeter

Similarly a fixed current is passed through an unknown resistance from a calibrated internal current source. By measuring the voltage drop across the resistance, the value of resistance can be read from the display. The basic schematic diagram of DMM is as shown in figure

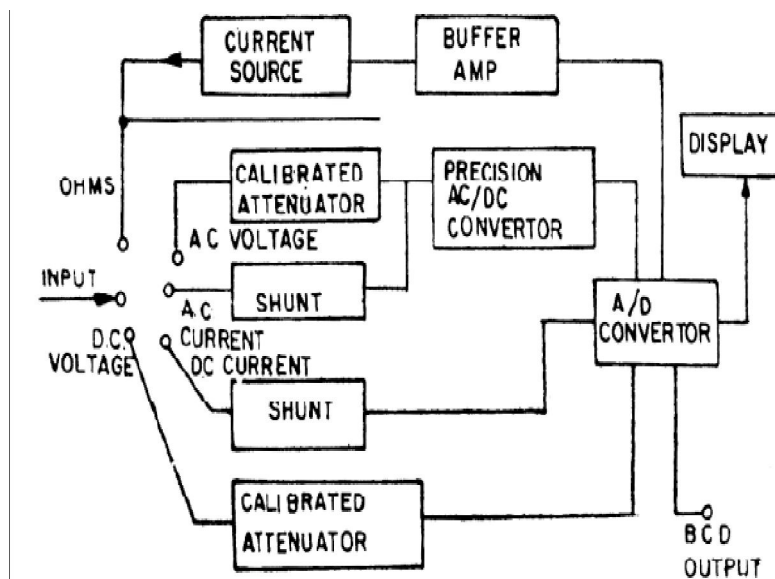

Fig. 5.5 Block diagram of DMM

### 5.7 Photo Electric Tachometer / Digital Tachometer

a) **Photo -electric Tachometer :** The Photo Electric tachometer is a Digital Tachometer

The basic constructional details of photo-electric tachometer is as shown in figure. It consists of an opaque disc D, which has equidistant and uniform holes or its periphery, a light source, L, a light sensor or photo sensitive semiconductor P and an electronic counter.



**Fig. 5.6 Use of Digital Tachometer**

When the tachometer is coupled to the machine, whose speed is to be measured, the shaft rotates. The disc D, also rotates along with shaft. The light falling on sensor P was interrupted by opaque portion of disc and a 'pulse' is produced in it with definite time interval, depending up on speed of machine. The output of sensor P is connected to an electronic counter and respective speed is denoted on the 'dial' or 'display'. to express the speed in rpm/rps in digital form.

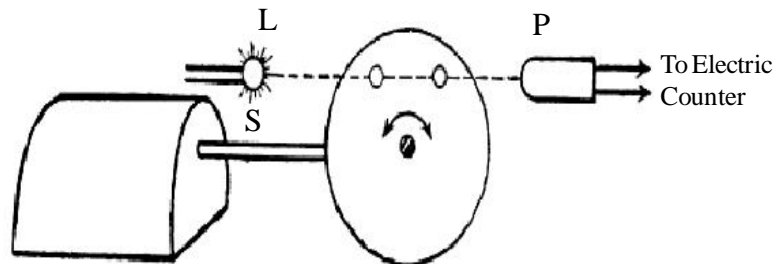

**Fig. 5.6 Digital Tachometer**

---

**Key concepts**

- Digital instruments – applications in electrical technology.

---

**Activity**

- Usage of digital instruments like multimeter, voltmeter, ammeter and tachometer
- Care and precautions while using digital instruments.

---

**On the Job Training/Project Oriented Questions**

- Precautions to be adopted while using digital instruments



## Semi Conducting Components

---

### Learning Objectives

After studying this unit, the student will be able to understand

- Fundamentals of semiconducting/electronic components
- Learn special diodes – PN junctions, Zenar diode, LED, LCD, Solar cell/Photo Voltaic array.

---

### 6.1 Introduction

The word ‘electronics’ is derived from electron mechanics, which means the study of behaviour of an electron under different conditions of externally applied fields. Electronics is branch of science and engineering, which deals with electron devices and their utilization. An electronic device is a device in which the conduction takes place by movement of electrons through vaccum, gas or semi-conductor.

The real beginning in electronics was made in 1906, when Lee De forest invented the vacuum triode. In 1948, the invention of the transistor by the three Nobel laureates - John Bardeen, Walter Brattain and William Shockely at Bell Laboratory has completely revolutionized the electronics industry. Transistors opened the floodgate to further developments in Electronics. Result of that, in early sixties, first integrated circuits appeared in the market. Due to rapid developments IC technology, it was happened to fabricate more than 300 000 components on single chip.

An electronic circuit may appear quite complicated and may be capable of performing fantastic functions. But all electronic circuits, however complicated, contain a few basic components such as resistors, capacitors, inductors, Tube devices and semi-conductor devices. The three were called passive components and two the remaining were active components.

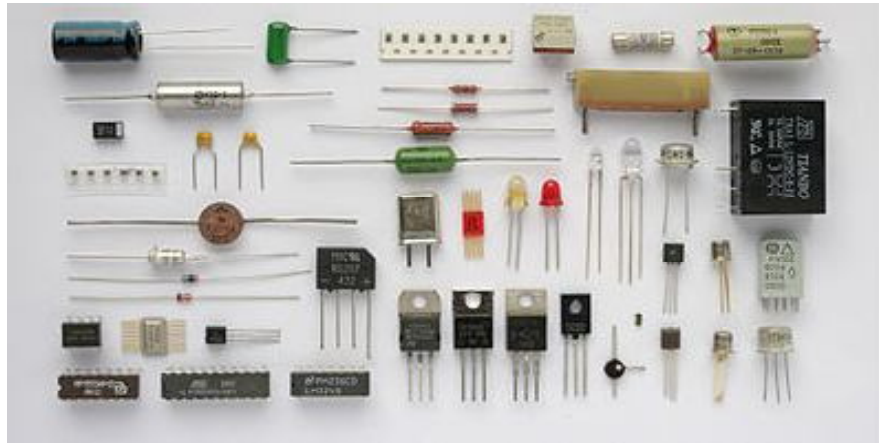
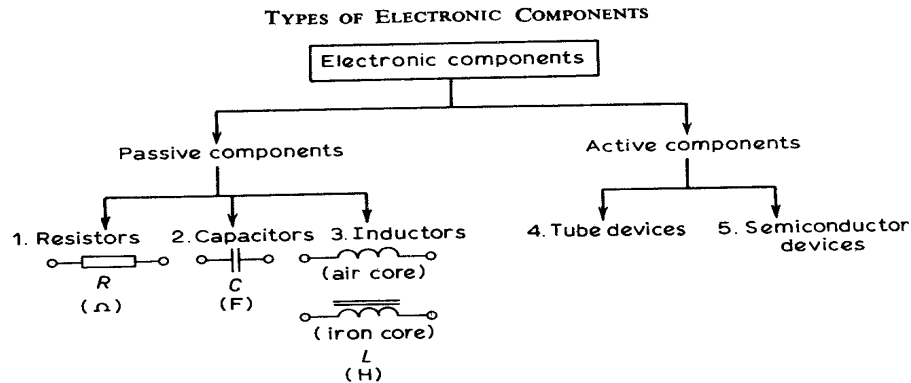

**Fig 6.1 Types of Electronic Components**

There are many active components used in electronic circuits. But all the active devices or components can be broadly classified into two categories, Tube type and Semiconductor type. Tube devices are prior to the semiconductor devices and they are replacing the tube devices in almost all electronic applications. In this chapter we focus our attention on some semiconductor devices.

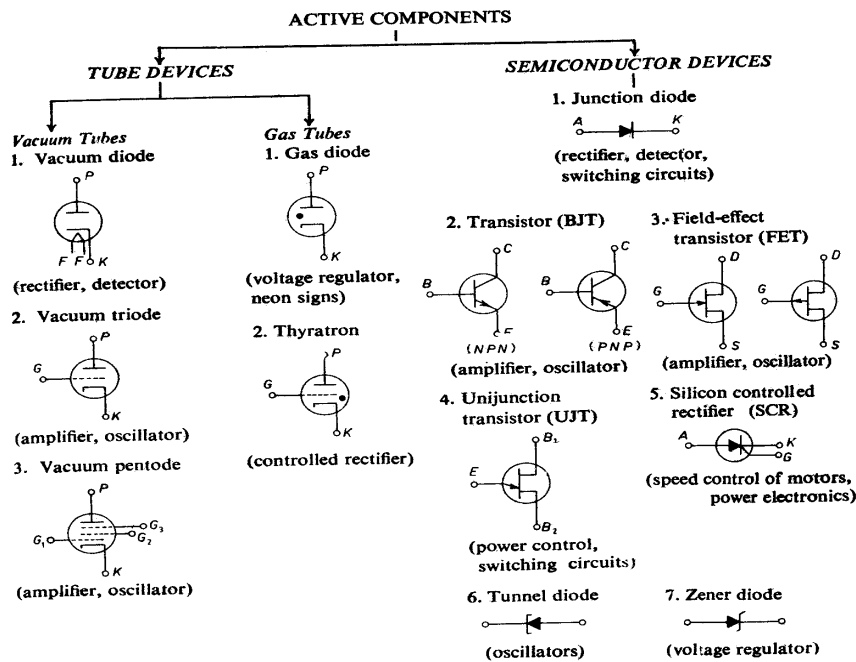

Fig 6.2. Active components

Certain substances like Germanium, Silicon, Carbon etc., are neither good conductors like Copper nor insulators like glass or wood. In other words, the resistivity of these materials lies in between conductors and insulators. Such substances are classified as semi-conductors. The devices or components which are made by semiconducting materials are called semiconductor devices. Semiconductor diode, Transistor, Integrated circuits etc., are best examples for semiconductor devices.

## 6.2 Conductors

1. Conductors or conducting materials will have plenty of free electrons. Hence they easily allows the passage of electric current through them.
2. The materials those have less than 4 valency electrons (i.e. 1 to 3), are called as conductors. e.g., Cu, Al.
3. The valence band and conduction band are overlaped each
4. They have very less resistance a conductor, a material must have a bulk resistivity within the range of  $10^{-6}$  to  $10^{-4}$  ohm-cm

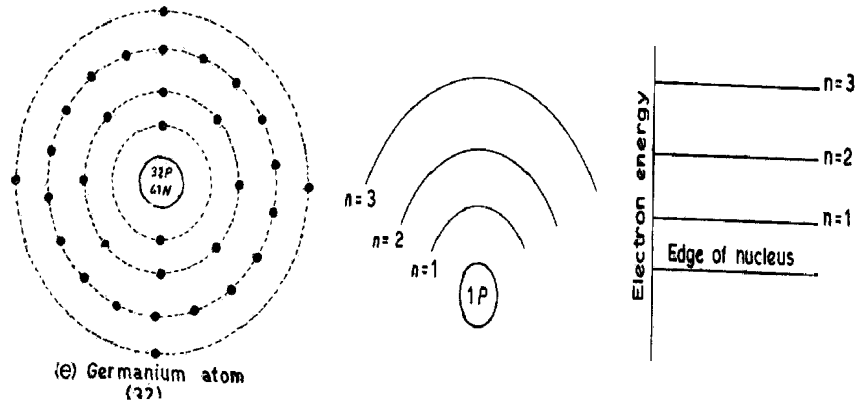

Fig 6.3 Atomic structure

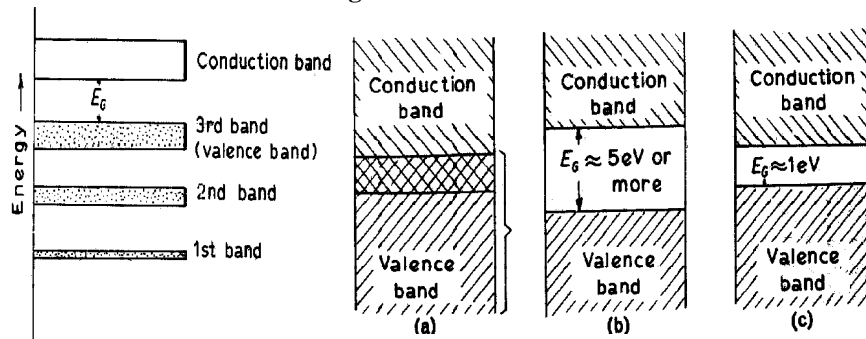

Fig 6.4. Energy band diagram of a) Conductors b) Semiconductors c) Insulators

### 6.3 Characteristics of Insulators

1. In insulators or insulating materials, the valency electrons are tightly bound to their parent atoms. There is no free charge carriers. Hence they do not allow the passage of electric current through them.
2. The number of valency electrons are more than four.
3. They have very wide energy gap between valency and conduction band (about 5 eV or more)
4. Insulators lose their properties and become conductors at very high temperatures
5. They have negative temperature coefficient of resistance.
6. The resistance varies between  $10^3$  to  $10^{22}$  ohm-centimeter
7. Examples for insulators - Glass, PVC, Mica.

## 6.4 Characteristics of Semiconductors

1. Materials whose properties lies between conductors and insulators are called semi-conductors. These are neither conductor nor insulators.
2. The number of valency electrons are *four*.
3. The energy gap between conduction band a valeny band is 1 ev.
4. The resistivity of semiconductor is less than insulator and more than conductor.
5. Semi-conductors have -ve temperature co-efficient of resistance.
6. When a suitable metallic impurity is added to a semi conductor its current conducting properties change appreciably.
7. Example. Silicon, Germanium, Carbon.
8. Semiconductors have bulk resistivity in the range of  $10^{-4}$  ohm-cm (heavily doped) to  $10^3$  ohm-cm (undoped, or intrinsic)

## 6.5 Types of Semiconductors

Semi conductors can be classified as below

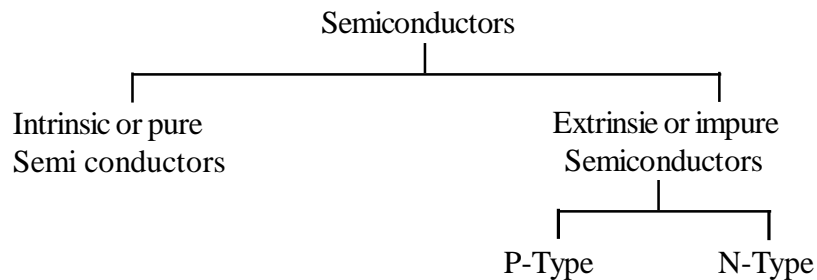

**Intrinsic semiconductor :** A semiconductor, extremely in pure form is called intrinsic semiconductor.

e.g., Pure Germanium and Silicon.

In this, the number of conduction electrons is equal to number of holes. At room temperature hole electron pairs are created. When electric field is applied across an intrinsic semiconductor, the current conduction takes place by two processes, namely by free electrons and holes. The total current inside the semiconductor is the sum of currents due to free electrons and holes.

**Extrinsic semiconductor** : When pure semiconductors added with some suitable impurity or doping agent or dopant about 1 part in  $10^8$  then it is called extrinsic semiconductor.

The usual doping agents are

- (1) Pentavalent atoms having *five* valence electrons  
(Arsenic, Antimony, Phosphorus)
- (2) Trivalent atoms having *three* valence electrons  
(Gallium, Indium, Aluminium)

Pentavalent atom is known as donor atom and the Trivalent atom is called acceptor. Depending on the type doping material (impurity) used, the extrinsic semiconductors can be sub- divided into two classes.

## 6.6 N-Type Semiconductor

When pentavalent material like Antimony, phosphorus is added to pure Germanium crystal (or pure intrinsic semiconductor) N-type semiconductor is formed. The material added as impurity is called donor. The donor makes four covalent bonds with Germanium atoms and the fifth electron is loosely bound to the antimony atom. The formation of N-type material leads an excess of electrons in its atomic structure. Hence it is called N-type material (N-Negative). The electrons are the majority carriers while holes (hole means missing of electron in covalent bond) are minority carriers.

## 6.7 P-Type Semiconductors

When a trivalent material (like Boron, lithium) is added to pure semiconductor, P-Type semiconductor is formed.

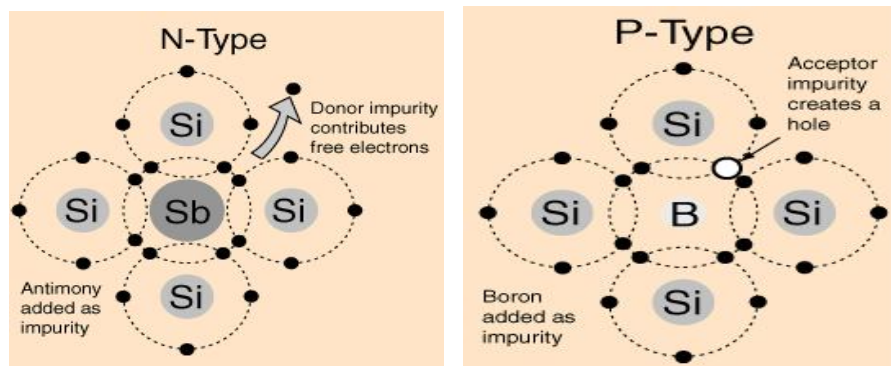

Fig. 6.5 Structure of P-Type and N-Type Semi conductor

The material added as impurity is called acceptor. The semiconductor makes three covalent bonds with acceptor and a hole is formed in semiconductor. The deficit of electrons makes the material acquire positive charge and hence it is called P-Type material. The holes are majority charge carriers and the electrons are minority carriers.

### 6.8 Comparison between P-Type and N-Type semiconductor

P-Type semiconductor	N-Type semiconductor
1. When Trivalent impurity like Boron, lithium is added to pure semiconductor, P-Type material is formed.	1. When pentavalent impurity like Phosphorus, Antimony is added to pure semiconductor, N-Type material is formed.
2. The impurity added is known as acceptor.	2. The impurity added is called as donor.
3. There is a deficiency in electrons, hence an excess of holes.	3. There is an excess of electrons.
4. The conduction of charge is due to holes.	4. The conduction of charge is due to electrons.
5. The majority carriers are holes and minority carriers are electrons.	5. The majority carriers are electrons and minority carriers are holes.

### 6.8 P - N Junction

When P-Type and N-Type semiconductors are fabricated on a single crystal by special techniques, a new semiconductor is formed. It is known as P-N junction or semi conductor diode. The most important characteristic of a P-N junction is its ability to conduct current in one direction only. In other words, it offers low resistance in one direction and very high resistance in other direction as almost insulator. Diodes are used as rectifiers.

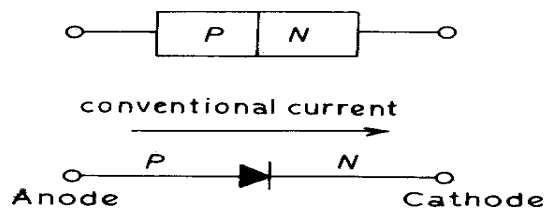

Fig 6.6(a) P - N junction symbol

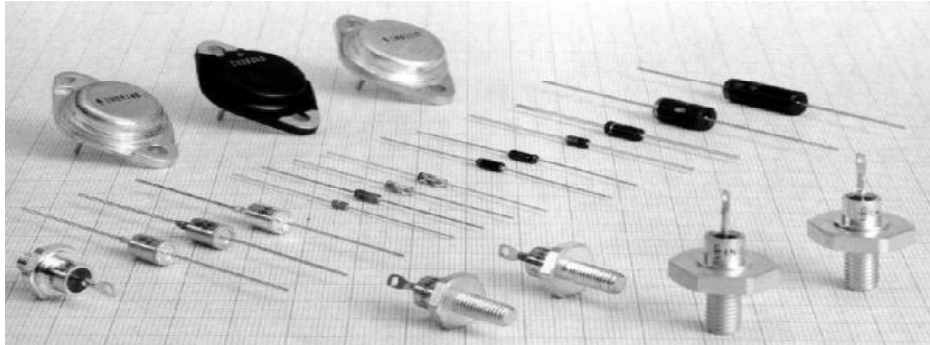

Fig 6.6 Real images of P-N junction diode.

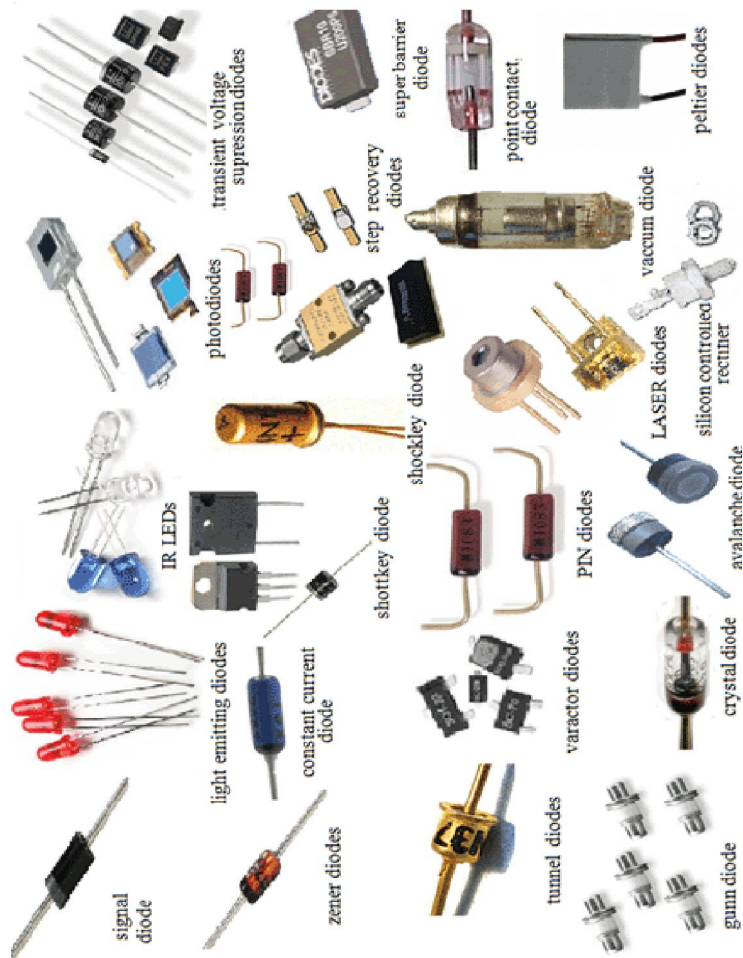

Fig. 6.7 Types of Diode

### 6.8.1 Working of P-N junction with no bias

(The method of applying voltage to P-N junction as is called Biasing of P-N junction or semiconductor diode). As soon as the PN junction is formed,



holes from the P-region diffuse into N-region and electrons in N-region diffuse into the P-region and combine with holes. This diffusion of free electrons and holes across the junction occurs for a very short time. The saturated atoms form as a barrier for further recombination of electrons and holes. This barrier is called potential barrier or depletion region.

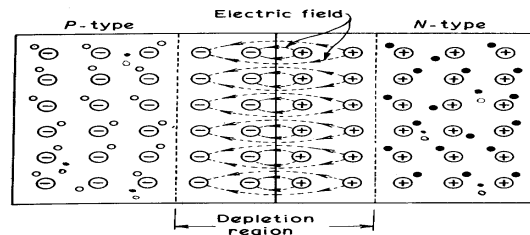

Fig 6.8 PN junction with no bias.

Thus barrier is developed across the P N junction with no bias.

### 6.8.2 Working of P-N junction with forward bias.

When P N junction is connected with a battery such that the P-side is connected to positive terminal and N-side to negative terminal of the battery as shown in fig., that type condition of P N junction is called as P N junction with forward bias.

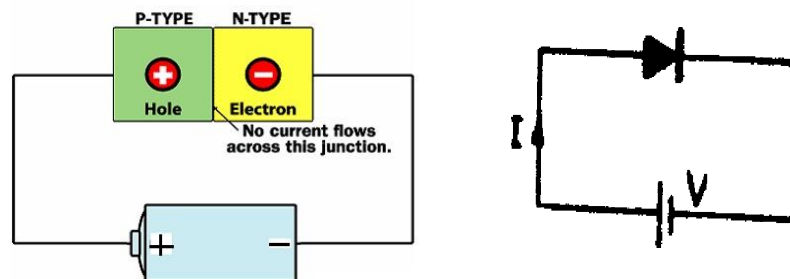

Fig 6.9 PN Junction with forward bias

When the P N junction is forward biased, the holes are repelled by the positive terminal of the battery and electrons repelled by negative terminal of the battery. They are compelled to move towards the junction. This reduces the potential barrier and the majority carriers diffuse across the junction and recombine. This causes a free path for flow of electric current through the junction and the junction starts conducting.

### 6.8.3 Working of PN junction with Reverse bias

When a PN junction is connected with a battery such that, the P-side is connected to negative terminal and N-side to positive terminal of the battery as shown in fig. That type of condition of PN junction is called as PN junction with reverse bias.

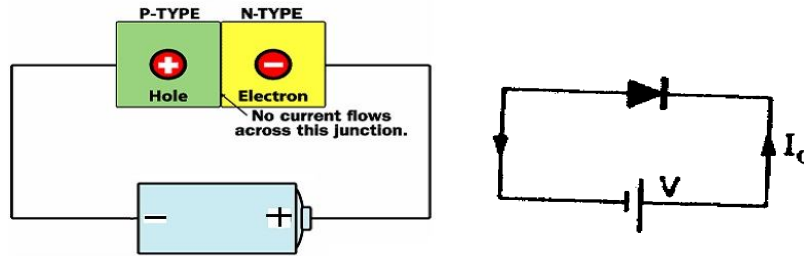

Fig 6.10 PN junction with Reverse bias.

When the PN junction is reverse biased. The holes attracted by negative terminal of the battery and electrons are attracted by positive terminal of the battery. Thus the majority carriers are drawn away from the junction. This action widens the depletion region and increases the barrier potential and reduces the possibility of any conduction of electric current through the junction, hence the junction doesnot conducts on reverse bias.

### 6.8.4 V - I characteristics of a PN-junction diode

The graph between the voltage applied across the terminals of a PN junction and resultant current passing through it, is called VI characteristic curve of PN junction diode. When the diode is forward biased and applied voltage is increased from zero, very small current will flow till the external voltage overcomes the barrier potential. After that, current through diode increases rapidly with the increase in applied voltage. These characteristics are called forward characteristics and the graph is known as forward characteristic curve.

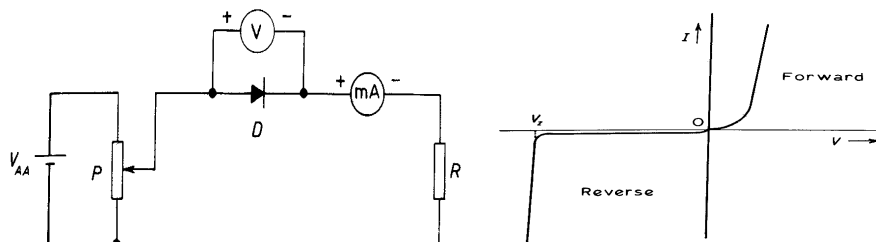

Fig 6.11 V1 characteristics of PN junction diode.

When the diode is reverse biased and applied voltage is increases from

zero, a very small current in order of nano amps or micro amplifiers) will flow due to minority carriers. Further increase is voltage, at certain value called breakdown voltages the leakage (or reverse current) suddenly and sharply increases. Any further increase in voltage in produce burnout of diode. These character istics are known as reverse chatacteristics and the graph is called reverse characteristic curve.

## 6.9 Zener Diode

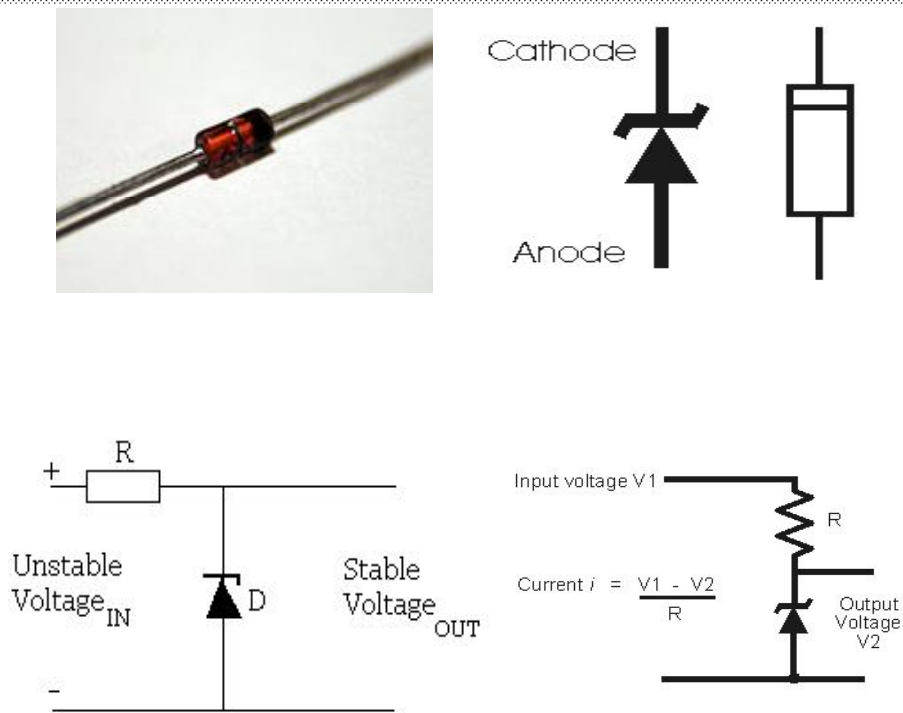

Fig 6.12 Zener Diode and its use

Zener diode is a Silicon P-N Junction diode. Its breakdown voltage is kept lower than that of an ordinary diode and each diode is designed to have a specific breakdown voltage.

### VI Charecteristics of Zener Diode

The typical VI Charecteristics of a zener diode are as shown in graph. The forward charecteristics are similar to ordinary diode. But its reverse charecteristics are different. When it is reverse biased, the amount of leakage current increase suddenly by increasing the reverse bias. The current flowing through the zener diode on breakdown voltage is called avalanche current or Zener current.

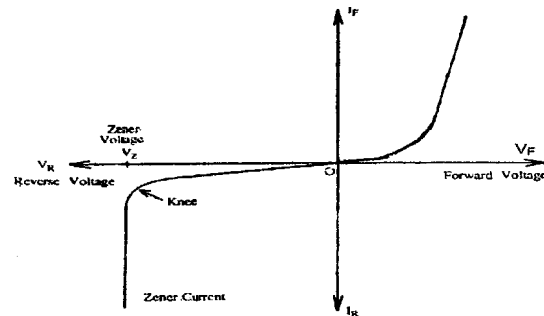

Fig 6.13 VI Characteristics of Zener Diode

### Applications

A Zener diode is used in voltage regulator circuits, biasing and comparison circuits, meter protection, motor protection (used in electronic equipments) calibration of voltmeters, etc.,

### 6.10 L.E.D ( Light Emitting Diode)

It is a special type of diode which is different from a conventional semiconductor diode. It employs a gallium-arsenide (GaAs) or gallium phosphide (GaP) PN-junction instead of a germanium or silicon. The device is used as a light indicator in electronic equipments.

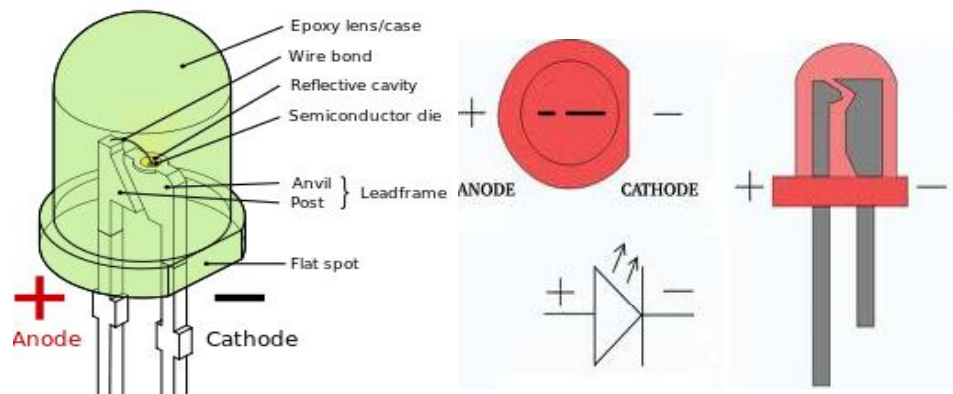

Fig 6.14 Light emitting diode

In a conventional diode, the heat developed during 'recombination' of holes and free-electrons is absorbed by the semiconducting materials. But in

LED, energy is released by the PN-junction in the form of light rays of visible and Infra-red spectrum when it was forward biased. They works with low voltage (1 to 3V) and takes 10 to 15mA current and available in 4 different colours Green, Red, Yellow and Blue.

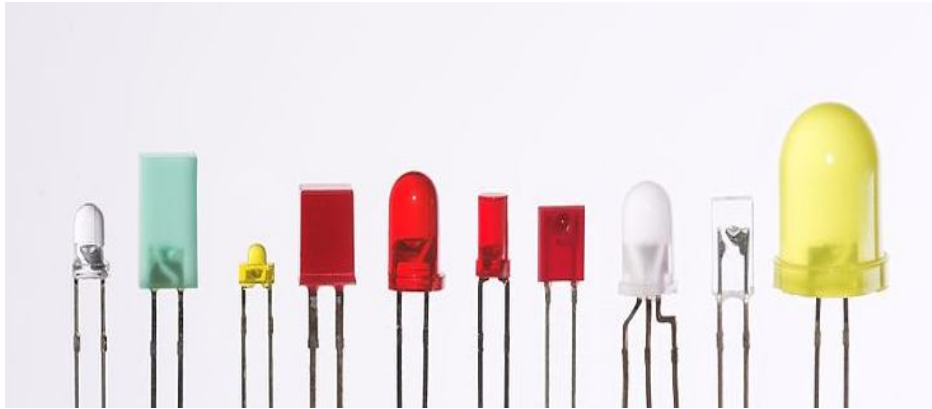

Fig 6.15 Light emitting diodes

### 6.11 L C D (Liquid Crystal Displays)

The LCD consists of an orderly arranged Liquid Crystal Cells. A liquid crystal is an organic material which flows like a liquid at room temperature. A Liquid Crystal Cell consists of a thin layer of LC sandwiched between two glass sheets with transparent electrodes. One glass is transparent and the other is reflective type. When the Liquid Crystal Cell is energised (applied with some voltage) the molecules of the liquid are disturbed and they absorb the incident light and give localized black display.

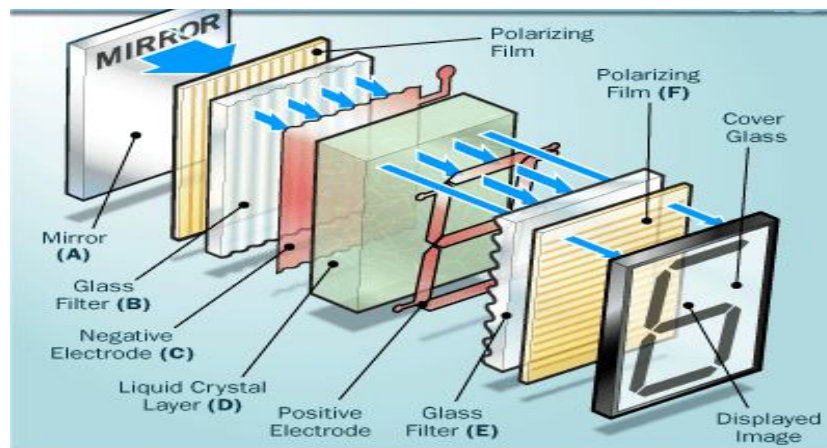

Fig 6.16 Liquid crystal display basic construction

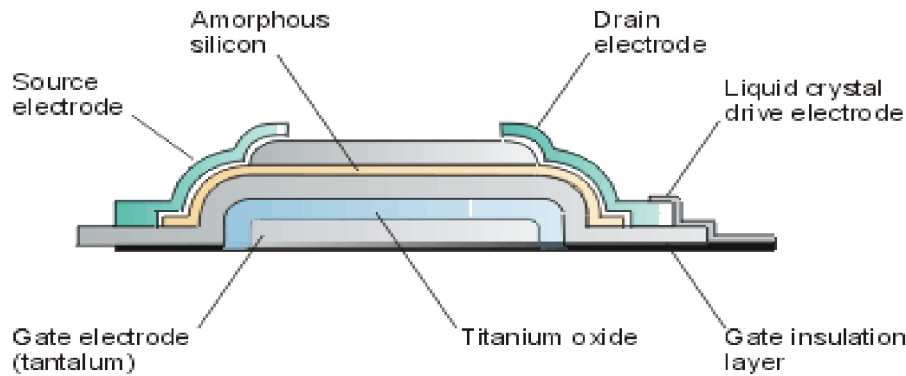

Fig 6.17 Liquid Crystal Display

**Application :** It is used in watches, portable electronic instruments digital displays, video monitors.

## 6.12 Varactor Diode

It is a P-N junction diode designed to work at high frequencies. Its internal capacitance depends on the voltage applied across it. The varactor Diode is used for amplification, frequency multiplication and switching purposes.

### VI Charecteristics of Varactor Diode

The graph shows, the variation of capacitance with reverse bias voltage.

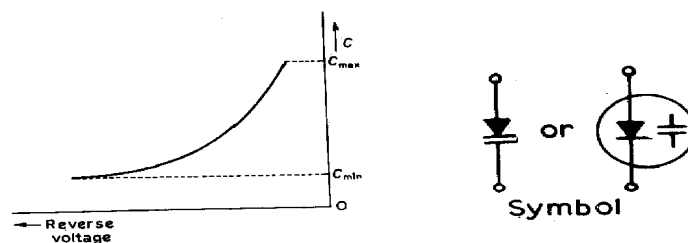

Fig. 6.18 Varactor Diode (a) Symbol (b) VI Charecteristics

### Tunnel diode

A tunnel diode is basically a heavily doped PN junction. The width of depletion layer is about  $100 \text{ \AA}$ . Due to the extremely thin depletion layer, electrons are capable of tunneling through one side of the junction to the other at very low forward bias voltage (0 to 5V). Generally, the tunnel diodes are made from Gallium Arsenide (GaAs).

### V I Charecteristics of Tunnel Diode

The V I Charecteristics of Tunnel Diode is different from ordinary PN junction. On reverse bias, because of there is no region of high reverse resistance (due to heavy doping). The diode appears as break down and conducts. Where as in forward bias, the current varies as shown in Charecteristic curve, because of tunneling phenomenon.

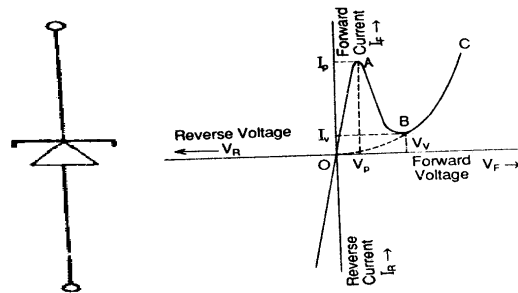

Fig. 6.19 Tunnel Diode and its Charecteristic curve.

**Applications:** It is used in Amplifiers, oscillators, switching devices, high frequency oscillators etc.,

### 6.13 Solar cells

A solar cell or solar battery is basically a heavily doped PN junction diode. It converts solar energy into electrical energy. It is made from Germanium, Silicon, Ga As , In As or Cd As. The PN junction is packed in a box, with a glass window on top, so that, light may fall on P and N type materials. The thickness of P and N regions are kept very small. A nickel plated ring is arranged on plate and acts as positive output terminal and a metal contact is arranged at the bottom, to act on negative output terminal (see the figure).

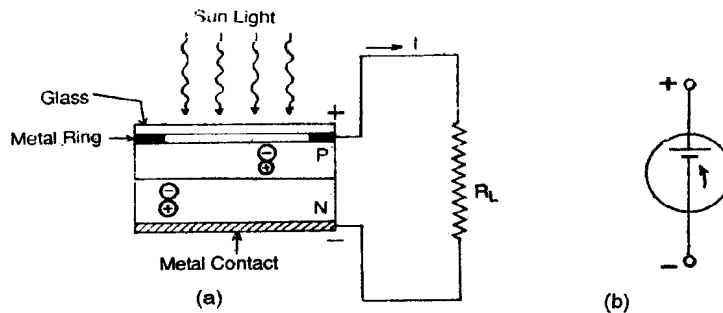
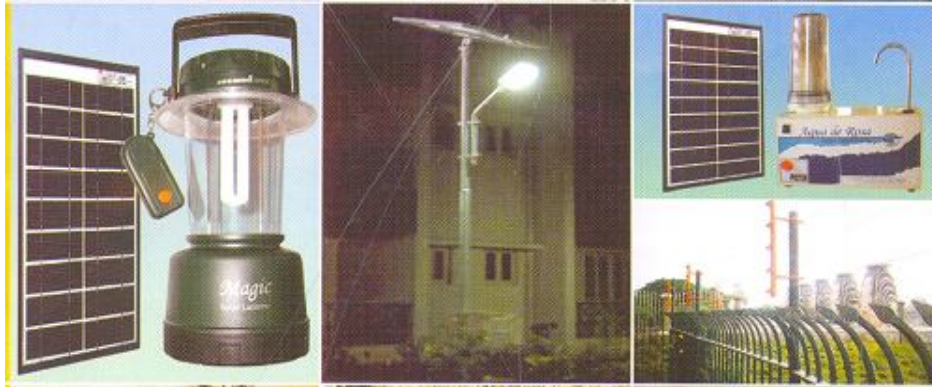

Fig 6.20 Solar Cell



When light falls on the PN junction, the valence electrons are activated and forms electrons-hole pairs. The majority carriers are obstructed by depletion layer, but the minority carriers slide down the barrier and constitutes current. Accumulation of electrons and holes on two sides of junction will produce circuit voltage about 0.6V. The current or the voltage developed is depends on the level of illumination and the surface exposed to light. A number of such anodes are connected in series and parallel and the energy so obtained is connected to a rechargeable battery.

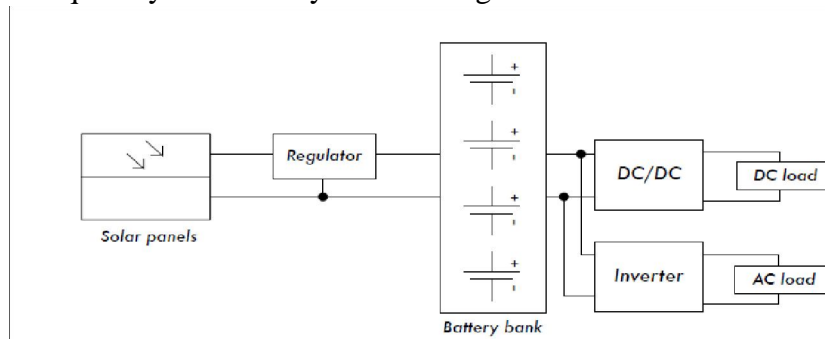

**Fig 6.21 Applications of Solar cells**

**Application :** Solar cells are Non conventional energy sources. They are used in satellites, space vechicles, solar lamps, solar water heater, solar pumpsets etc.,

### 6.14 Photo - Voltaic cells.

The photo voltaic cells are the devices, in which light energy is used to create a Potential Difference. The Potential Difference developed is praportional to frequency and intensity of incident light.



**Fig 6.22 Block diagram for Solar Power Supply System**



It consists of a semiconductors like, Cuprous oxide or Iron selenide, coated with a metallic film of silver, gold and platinum. It was attached to a metal base plate. When the light falls on the metallic film, photo emission occurs and the photo electrons move towards the metallic film. The metallic film becomes negatively charged and the metal base or base plate becomes positive. Hence a potential difference is developed and acts as a energy source.

**Application :** These are used in photo graphic exposure meters, Illumination meters, operation of relays etc.

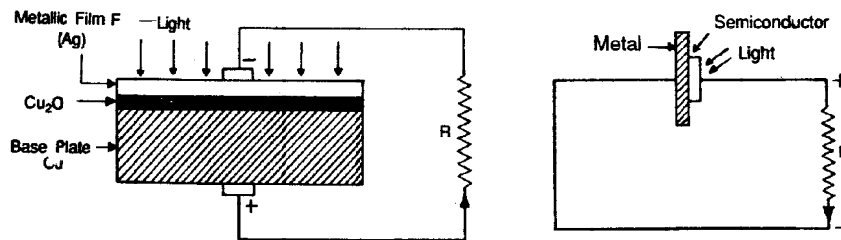

Fig 6.23 Basic construction and symbol of photo voltaic cell

## 6.15 Transistor

Transistor was invented by John Bardeen and others in 1948 at Bel Laboratory, America. Transistors have several advantages over Vacuum tubes. A Transistor is basically Silicon or Germanium crystal containing three separate regions.

There are two types of transistors., namely N P N and P N P transistor the middle region of transistor is called base and the two outer regions are called emitter and collector.

**Base (B) :** It is very lightly doped and is thin in size. The function of base is to pass the majority carriers (i.e., electrons in N P N transistor or holes in P N P transistor) to collector.

**Emitter (E) :** It is heavily doped and little larger than base. The main function of emitter is to emit or inject the electrons or holes into base.

**Collector (C) :** The doping level of collector is between the doping of emitter and base. The function of collector is to collect the charge (electrons or holes ) from the base

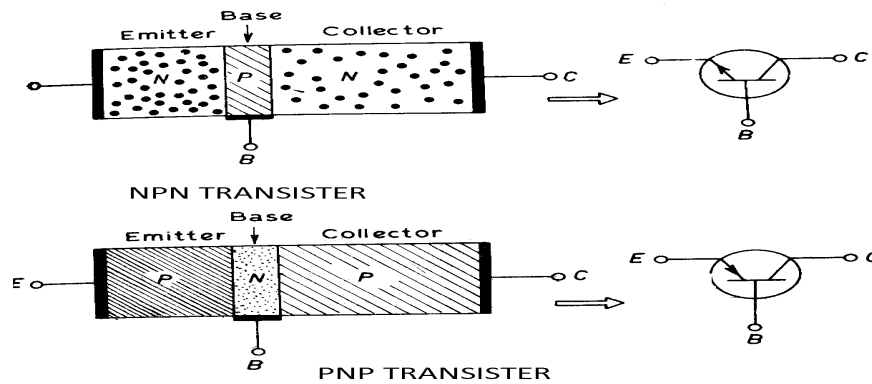

Fig 6.24 Transistor

A transistor consists of two PN junctions formed by sandwiching either P-type or N-type semiconductor between a pair of opposite types and separated by a thin section of P-type and a PNP transistor is formed by a thin section of N-type semiconductor. A transistor transfers a signal from a low resistance circuit to high resistance circuit.

### 6.16 Transistor configurations or transistor connections.

A transistor can be connected in a circuit in the following three ways.

- (i) Common Base configuration
- (ii) Common Emitter configuration
- (iii) Common Collector configuration

The three terminals of transistor can be connected in such a way that, one terminal is common to both input and output terminals. Each circuit connection has specific advantages and disadvantages. But regardless of circuit connections, The emitter (or emitter- base junction) is always forward biased, while the collector (or collector - base junction ) is reverse biased.

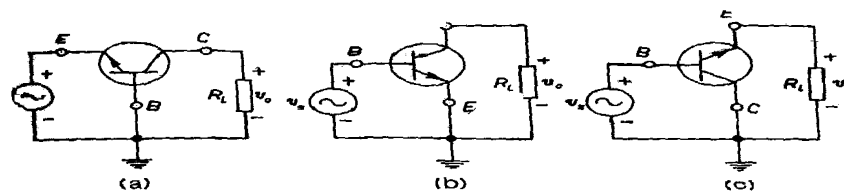

Fig. 6.25 Configuration of Transistor (NPN Type)

### 6.17 UJT (Uni Junction Transistor)

It consists of a single P-N junction and made with silicon. Its N-region is kept large than P-region. Two leads are connected to the N-regions as shown figure.

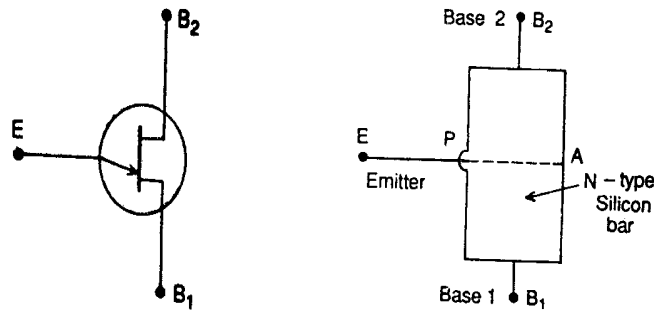

Fig. 6.26 UJT (Uni Junction Transistor)

The two terminals are called base-1 and base-2, P-region is called Emitter. In common type circuit, base-1 is grounded and the positive signal is applied to base-2. The N-region acts as a voltage divider. Hence, a positive potential is maintained on the junction.

If the magnitude of emitter voltage is lesser than the voltage present on the base the transistors will remain in reverse bias state. When the emitter voltage exceed the voltage present on the base, the transistor will be changed into forward bias state and the holes will start to reach the base-1 region by crossing the emitter junction.

In this way, the conduction of emitter current will start and the effective resistance of the junction will be reduced. It will produce a rise in the emitter voltage.

### 6.18 Field Effect Transistor

FET or JFET (Junction Field Effect Transistor) is a three terminal unipolar, solid-state device. In this transistor, the current is controlled by an electric field as in vacuum tubes.

An FET can be fabricated with either N-channel or P-channel. But, N-channel is preferred. For fabricating N-channel FET, a narrow bar of N-type semiconductors is taken and two P-type junction are diffused on opposite sides of its middle part.

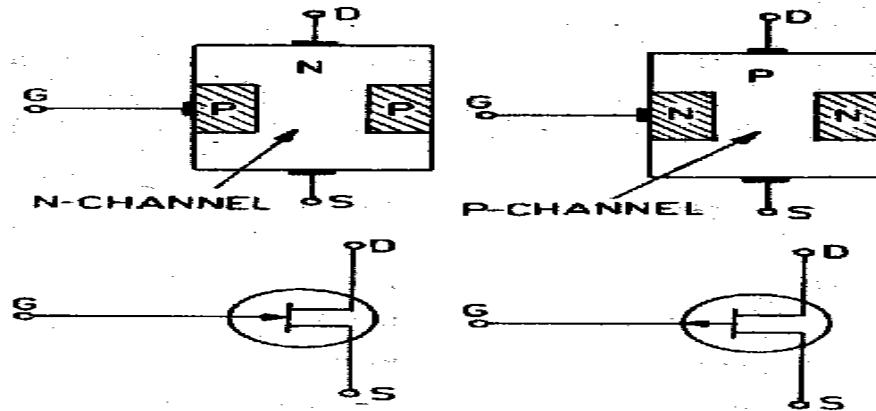

Fig 6.27 Construction and symbols of FET

These two junctions from two P-N diodes or gates and the area remained between the two gates is called the channel. The two gates are connected internally and single connecting lead is brought out of the device which is called the gate terminal. Two leads are joined to the bar, are on each side and they are called the source and Drain.

P-channel FET is similar in construction except that it uses P-type bar and two N-type junctions.

- (i) **Source** : The terminal through which majority carriers enter the channel.
- (ii) **Drain** : The terminal through which majority carriers leave the channel.
- (iii) **Gate** : The terminal formed by joining internally the two impurities regions. It controls the travelling of majority carries from source to Drain.

### Working

In an N-channel FET, the source terminal is connected to the negative and the drain terminal to the positive of the battery. The gate is always reverse-biased. When  $V_{GS}$  is 0 and  $V_{DS}$  is 0 then  $I_D$  is also 0. On increasing the  $V_{DS}$  from 0, the  $I_D$  starts to flow in a linear manner ( with  $V_{GS}$  still 0); this current is also called Zero-gate-voltage-drain current. The current  $I_D$  is controlled by the gate voltage (-ve). In this type of transistor, the current is composed of only one type of charge carriers i.e., ( major carriers) ( electronics in case of \_\_\_\_\_ N-channel and holes in case of P-channel). Hence the device is called a unipolar Device.

### Advantages

- (1) High input impedance
- (2) small size, rugged and long life
- (3) Low noise, good high frequency response.
- (4) better thermal stability
- (5) High power gain.

### Applications

It is used in

- (1) electronic testing instruments.
- (2) In logic circuits.
- (3) As “mixer” of FM in TV receivers.
- (4) As VVR ( voltage - variable-resistor) in operational amplifiers and tone control circuits of audio amplifiers.
- (5) In computers for large scale integration (LSI), in memory circuits.

## 6.19 SCR ( Silicon controlled Rectifier)

A silicon controlled Rectifiers or SCR is a solid state equivalent device of thyatron. It consists of a P-N alloy junction and a differed P-N-P silicon transistor joined together the construction and symbol of SCR are as shown in figure.

### Construction

Its main part is the P-N rectifier. The N-P-N transistor is differed as a in the N- region of the rectifier these two sections together form a PNPN Silicon device. The rectifier has an anode and a cathode and the PNP dot is called gate.

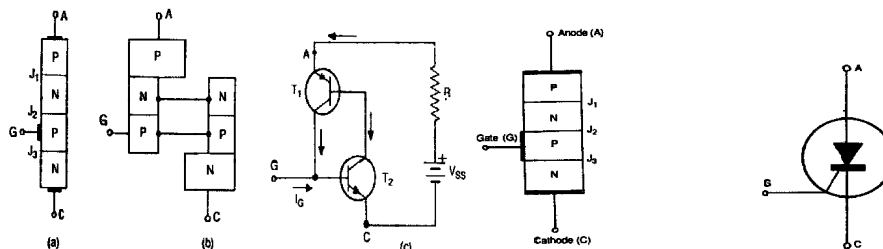

Fig. 6.28 SCR

In this way, a SCR has three terminals named as anode, cathode and gate and the remaining P-terminal acts as the gate.

### **Working**

The device acts in such a way that no current conducts through it till a definite positive voltage is applied at the gate even if the normal positive and negative voltage are being present on the anode and the cathode respectively. Similarly, in the reverse bias state also the conduction of current does not start below the breakdown or avalanche voltage being present across the device.

If a SCR starts to function on 18 volts and the voltage present across it is 17 volts (i.e., one volt less than the required value) the SCR will not conduct.

When a signal of 1.5 V , 30 MA is applied to the gate, the SCR will start to conduct and it will continue to conduct till it is not switch 'off' completely at least for 20 micro seconds.

Once the conduction of current is started the function of the gate is finished and the magnitude of current is than controlled by varying the load resistor or the supply voltage.

### **V I Charecteristics of SCR**

The graphical representation of relation between current and voltage of a SCR when it was forward and reverse biased. A small leakage current flows when it was in reverse base and even in forward bias. When it was forward biased, on application of a short pulse at gate, SCR starts conducting. To bring SCR to off position, the anode voltage should be brought down.

### **Applications**

A SCR can conduct 30 to 100 amperes of current. It is used in switching circuits, Regulated power supplies. Radar modulators servo system and electronic ignition system etc. It cannot be used for amplification purpose.

### **Key Concepts**

- Semiconductors, basic electronic components and their applications

### **Activity**

- Collect electronic components from old electronic equipments like radio, TV, mobile phone, Fused CFL lamp and identify them.
- Identify, connect and test various diodes/electronic components discussed in the lesson.

**Short Answer Type Questions**

1. Define conductors, semiconductors and insulators.
2. Define valency electrons, valency band.
3. Classify the semiconductors.
4. Write the comparison between P-type and N-type semiconductors.
5. Name the basic types of transistors and draw their symbols.
6. Draw the symbols for
  - a). UJT b). FET c). Zenar Diode d). Tunnel Diode e). LED
  - f). Solar Cell g). Photovoltaic Cell h). Photo Diode i). Photo Transistor.
7. What are the types of FET's? Mention their applications.

**Long Answer Type Questions**

1. Define PN junction. Explain its working when it was
  - a) No Bias b) Forward Bias c) Reverse Bias.
2. Define Zenar Diode. Write about its practical use with circuit diagram.
3. Explain the construction and working of SCR.
4. Write a brief note on
  - a). LCD b). Photovoltaic cell c). Tunnel Diode

**On the Job Training/Project Oriented Questions**

- Identify the component
- Learn connecting methods of vaious components
- safety mesures to be followed while assembling a kit for voltage stabilizer, inverter, UPS etc.

UNIT

7

## Power Supplies

### Learning Objectives

- Role and purpose of power supply in electrical appliances/equipments/ installations
- DC-AC power supplies
- New approach in Power supply like Inverter, UPS etc.,

### 7.1 Introduction

A power supply is a unit which is designed to operate at the available source of supply such as A.C. mains or 3-phase A.C or D.C. etc., and feeds an equipment as per requirements of the same. This unit may be a part of the equipment or may be made as a separate unit.

There main types of power supplies are given below.

1. A.C mains power supply
2. Voltage stablizer type power supply
3. Voltage regulator type power supply.
4. Convertor type power supply.(AC to DC)
5. Inverter type power supply.(DC to AC)
6. S.M.P.S. ( Switch mode power supply)
7. U.P.S ( Uninterruptable power supply).



In this, we focus our attention on converter type power supplies. Basically, the converter type power supply is a rectifier. It consists of a step down transformer, a rectifier, a filter and a voltage regulator.

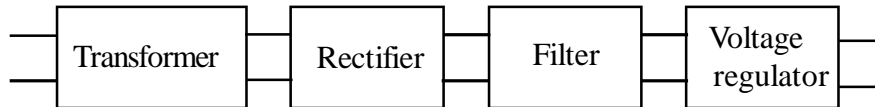

Fig 7.1 Block diagram of Power supply unit

## 7.2 Rectifiers

Now a days A.C. is employed as a source of electricity all over the world because of its easy and economical production and distribution.

Through A.C. is suitable for most of the electrical applications but there are some other applications of electricity for which D.C is essential e.g., (1) Electroplating (2) Electro-typing (3) Arc lamp (4) Battery charging etc. All the electronic equipments run with DC supply only. Hence it becomes necessary to convert A.C into D.C

The conversion of A.C. into D.C. is called rectification. The unit employed for rectification is called rectifier. *The process of conversion of A.C into D.C. is known as rectification.*

### Rectifiers are Following Types

1. Diode valve rectifiers
2. Metal rectifiers
  - (i) Selenium rectifiers
  - (ii) Copper oxide rectifiers
3. Solid state rectifiers

Again the rectifier circuits may be classified into following three main classes.

- (1) Half - wave rectifier
- (2) Full - wave rectifier
- (3) Bridge rectifier.

All the above three types of circuits can be made by employing valve, metal or solid state rectifiers.

### 7.3 Half - Wave Rectifier (By using Semiconductor Diode)

A Rectifier circuit designed with a single - diode which provides on output, only for half - cycle of A.C. (only for positive half - cycle) is called a half - wave rectifier.

In half-wave rectifier the rectifier conducts currents during the positive half-Cycles of input A.C. supply only. The negative half - cycle of a.c. supply are suppressed during negative half-cycles. The diode is reverse biased and no current is conducted and hence no voltage appears across the load. Therefore current always flows in one direction (i.e d.c) through the load

But the efficiency of a half-wave rectifier is poor and a multistage filter circuit is required for the conversion of pulsating D.C into smooth DC

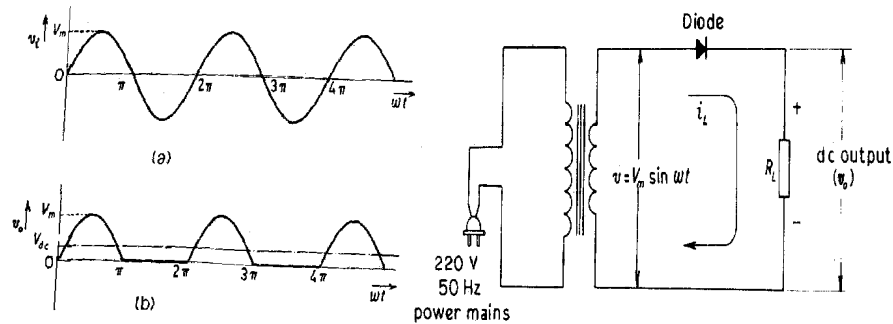

Fig 7.2 Half Wave Rectifier

### 7.4 Full-wave Rectifier

In full-wave rectification, current flows through the load in the same direction for both half-cycles of input a.c. voltage. This can be achieved with two diodes working alternately. For the positive half-cycle of input voltage, one diode supplies current to the load and for the negative half-cycle, the other diode does so. Current being always in the same direction through the load. Therefore, a full-wave rectifier utilises both half-cycles of input a.c. voltage to produce the d.c. output.

#### 7.4.1 Full wave Rectifier by using Centre tapped Transformer

The basic circuit arrangement is as shown in figure. It consists of a Centre tapped transformer, two diodes. The load is connected as shown in fig. During the positive half-cycle, the anode of the diode  $D_1$  becomes positive and the flow of electrons takes place through the diode  $D_1$  (cathode to anode), secondary windings upper section and the load resistor  $R_L$  the diode  $D_2$  remains inactive during this period.

During negative half-cycle the diode  $D_1$  remains inactive but the flow of electrons takes place through the diode  $D_2$  due to positive potential of the lower terminals of the secondary winding.

In this way, output is obtained for each half-cycle because of alternate functions of the two diodes.

The ripple frequency of the circuit is double of the supply frequency (normally 100 Hz). The circuit has a higher efficiency and due to flow of currents opposite directions through the two sections of the secondary winding

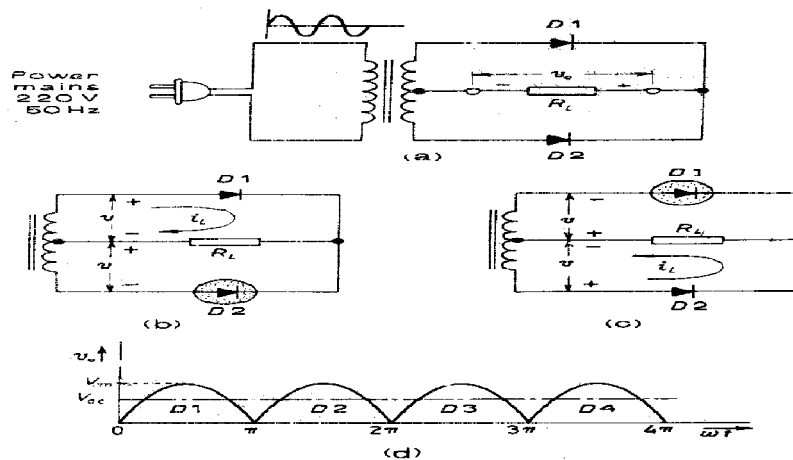

Fig 7.3 Full Wave Rectifier by using centre tap transformer

### Disadvantages

- (i) It is difficult to locate the center-tap on the secondary winding.
- (ii) The d.c. output is small.
- (iii) The diodes used must have high peak inverse voltage.

### 7.4.2 Full-wave bridge rectifier

As the name indicates, it is a full wave rectifier. It consists of four diodes and connected like *wheat stone bridge circuit*, hence the circuit is known as bridge circuit, hence the circuit is known as bridge circuit. (It contains four diodes  $D_1$ ,  $D_2$ ,  $D_3$  and  $D_4$  connected to form bridge as shown in circuit diagram

The a.c. supply to be rectified is applied to the diagonally opposite ends of the bridge through the transformer. Between other two ends of the bridge the load resistance  $R_L$  is connected

**Operation :** During the positive half-cycle of secondary voltage, the end P of the secondary winding becomes positive and the end Q negative, this makes diodes  $D_1$  and  $D_4$  forward biased while diodes  $D_2$  and  $D_3$  are reverse biased. therefore, only diodes  $D_1$  and  $D_4$  conduct. Hence current flows from A to B through the load  $R_L$ .

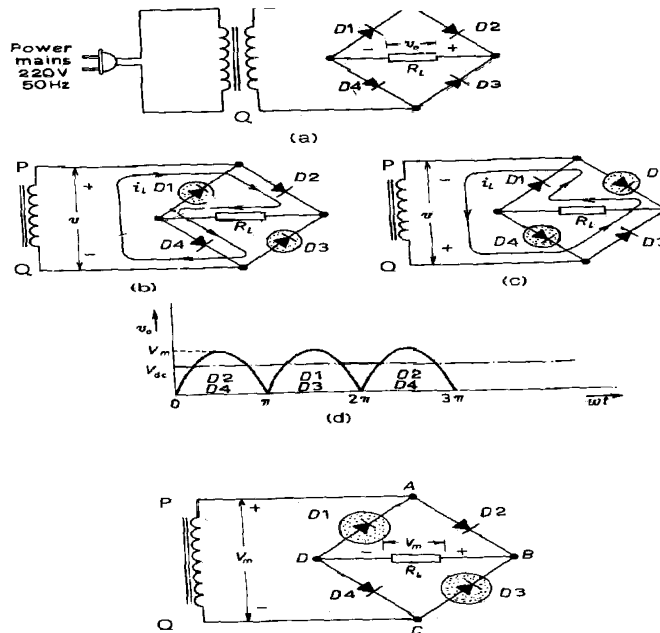

**Fig 7.4 Bridge Rectifier**

During the negative half-cycle of secondary voltage end P becomes negative and end Q positive, this makes diodes,  $D_2$  and  $D_3$  forward biased where as diodes  $D_1$  and  $D_4$  are reverse biased, therefore, only  $D_2$  and  $D_3$  conduct. The current flows from A to B through the load i.e. in the same direction as for the same positive half-cycle therefore, d.c. output is maintained across load  $R_L$ .

#### **Advantages of full-wave bridge rectifier**

- (i) The need for centre tapped transformer is eliminated.
- (ii) The output is twice that of the centre -tap circuit for the same secondary voltage.
- (iii) The peak-inverse voltage is one-half that of the centre-tap circuit.

### DisAdvantages

- (i) It requires four diodes.
- (ii) Internal voltage drop is more.

## 7.5 Metal Rectifiers

The metal rectifiers are of following two types.

- (1) Selenium rectifier
- (2) Copper oxide rectifier.

A number of selenium or copper oxide rectifiers may be connected in series for the rectification of high voltages as required.

### (a) Selenium Rectifier

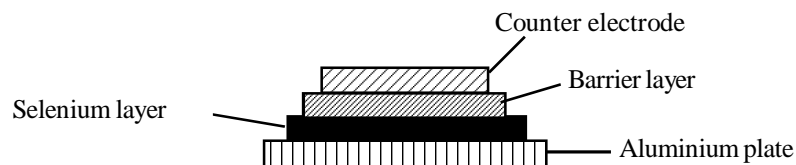

**Fig 7.5 Selenium Rectifier**

It consists of two metallic plates made of iron or Aluminium, A layer of 0.05mm thick of selenium is coated by heat treatment on one side of a plate. A counter electrode is made on the selenium layer by spraying an alloy metal having low melting point. A barrier layer is also formed by chemical action between the selenium and counter electrode layers.

The metallic plate acts as anode and counter electrode as cathode, the rectifier operates at 6 volts but it can with stand an inverse voltage of 18 volts. Its current density is 35 to 40 mA / cm<sup>2</sup> and its efficiency is 50 to 75 percent.

### (b) Copper-oxide rectifier

It consists of a copper plate which is coated with a layer of copper-oxide.

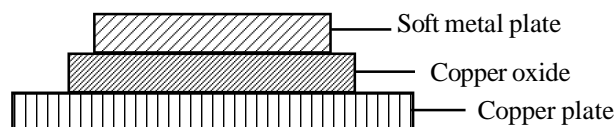

**Fig 7.6 Copper Oxide Rectifier**

The copper plate is allowed to cool down slowly in the air after heating it upto  $1000^{\circ}\text{C}$  temperature; Red hot copper combines with the oxygen present in the air and prepares a copper-oxide layer on it self. On side layer is cleaned off by chemical action and a counter electrode is made on the other side layer.

The counter electrode is made with an alloy metal having low melting point. The copper plate acts as anode and the alloy metal electrode as cathode The current density of the rectifier is  $0.1$  to  $0.5 \text{ A/mm}^2$ .

This rectifier can be operated at  $6$  volts and its efficiency is  $70\%$  to  $80\%$ .

## 7.6 The Need for Filter

The output of a rectifier contains a.c. ripple too in addition to the d.c. in order to obtain pure D.C., a.c. ripples should necessarily be removed.

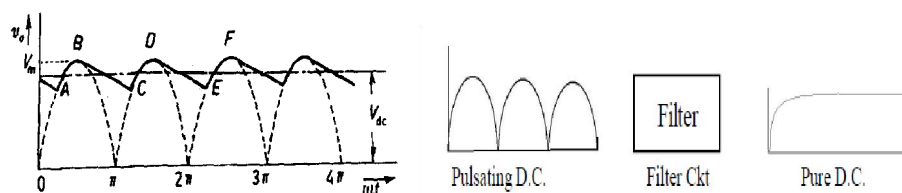

Fig 7.7 Function of Filter

Filters are used to reduce or filter the a.c. components in the output of a rectifier. Filter is a circuit which reduces the a.c. component from the output of rectifier.

A filter circuit is a device which removes the a.c. components of rectifier output but allows the d.c. component to reach the load. Obviously, a filter circuit should be installed between the rectifier and the load as shown below figure

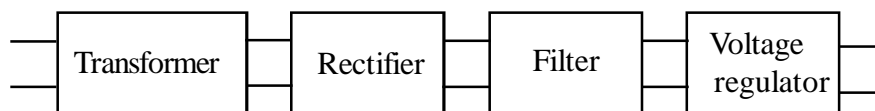

Fig 7.8 Location of Filter

## 7.7 Different Types of Filters

A filter circuit is generally a combination of inductor (L) and capacitor (C). The filtering action of L and C depends upon the basic electrical principles.

The filter circuit may be classified in the following three manners.

- (i) According to work.

(ii) According to input component

(iii) As per circuit design.

But the filters used in rectifiers are of following types.

(a) Capacitor filter

(b) Choke input filter

(c) Capacitor input filter or  $\pi$  Filter.

## 7.8 Inverter

Inverter is a circuit which converts dc power into ac power at desired voltage and frequency. This transformation is made with help of thyratrons, mercury arc rectifiers or SCR's along with capacitors or resistors and both. Inverters are used for domestic and industrial applications like variable speed ac motor drives, induction heating, air craft power supplies, un-interrupted power supplies (UPS) etc. There are two types of Inverters

a) Single phase inverters

b) Three phase inverters

When the main supply is available, voltage sensor reacts and simply passes the AC main supply to the output socket of Inverter directly. Mean while some part of AC main supply is converted to DC by rectifier and stored in battery.

On interruption/failure of main AC supply, voltage sensor reacts and activates the function of inverter circuit. The DC power stored in battery is converted into AC and supplied to the output socket of Inverter.

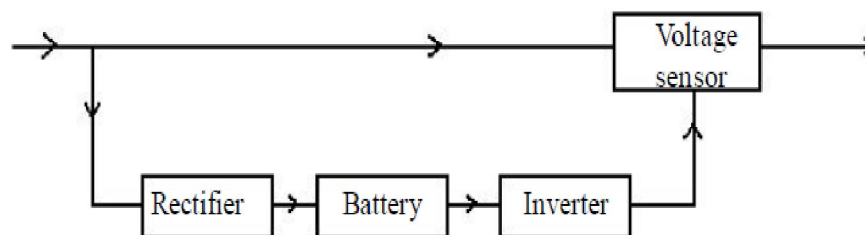

Fig 7.9 Block diagram of simple Inverter

## 7.9 Single Phase Inverter with SCR

The following three circuits are popularly used in single phase inverters.

- Using centre tapped dc supply
- Using centre tapped load
- Using single phase bridge.

The practical circuits will have turn off components, return circuit diodes and wave form improvent circuitary along with storage battery and other. Tghe entire unit in called uni-power supply or uninterruptured power supply. By making appropriate connections with the practical Inverter, it automatically starts when the main power supply fails.

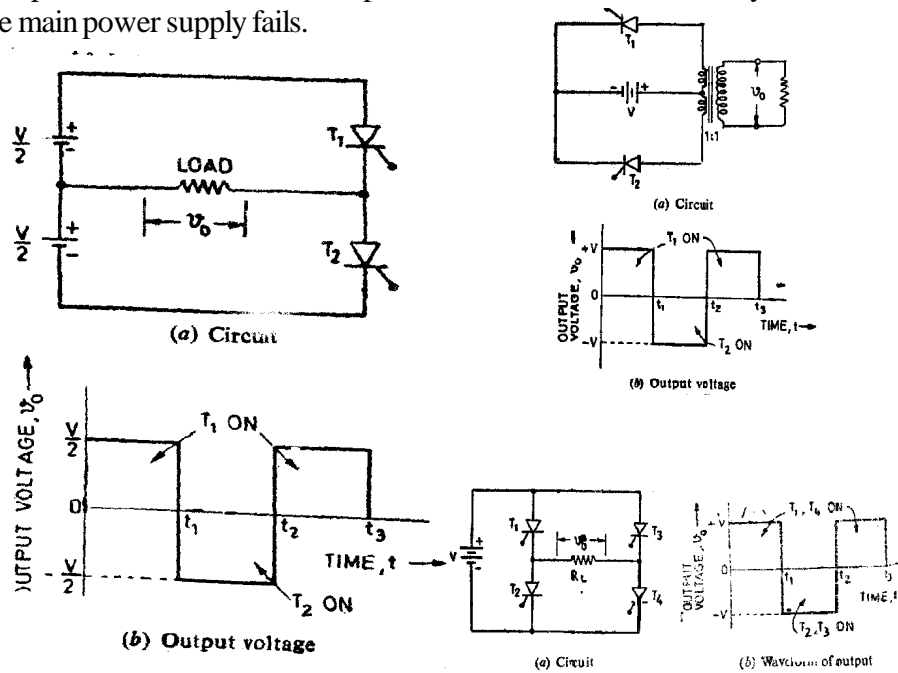
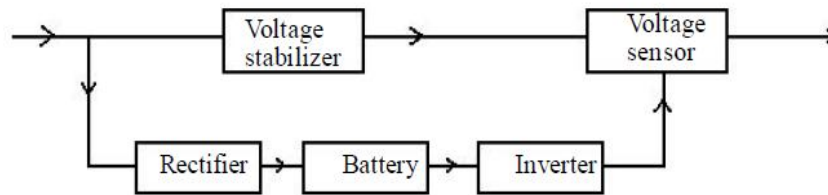

Fig 7.10 Basic Inverter Circuits

## 7.10 Uninterrupted Power Supply (UPS)

UPS (Un interruptable Power Supply) is an equipment which provides spike free, distortion free, noise free and stabilized power supply to the load. It is connected in series between mains supply and load. It also supply electric power for a limited period (stand by source) in case any failure of mains supply till the arrangement of alternate supply.





**Fig. 7.11 Block diagram of UPS**

The standard UPS consists of surge suppressor, automatic voltage regulator charger circuit, battery, inverter and changeover/transfer mechanism.

When the AC supply is available, it is filtered/regulated by surge suppressor and automatic voltage regulator and passed to the load through voltage sensor/changeover switch directly. Mean while some part of AC is converted into DC by rectifier and stored in storage battery.

On inturrption/failure of mains AC supply, voltage sensor reacts and activates the function of inverter. The DC power stored in battery is converted to AC by inverter and supplied to the load through voltage sensor/changeover switch.

Thus UPS provides smooth and inturrption free AC supply. Basically UPS systems are two types.

- a) Stand-by UPS
- b) On line UPS

The stand-by UPS are economical and low KVA rating(0 to 15 KVA).In this type the inverter starts its function on failure of AC mains supply. Where as in On-line UPS, the inverter is always 'ON' and they are available upto 5000KVA rating.

## 7.11 Voltage Stabilizer

Voltage stabilizer is also a common domestic appliance. It is necessary to maintain a constant voltage for refrigerator, television, computer etc., The excessive voltage ( $> 230V$ ) or low voltage ( $< 230V$ ) will damage the appliance. In order to safe guard the appliances, voltage stabilizers are used.

Many electrical/electronic equipments needs constent voltage for their smooth, accurate and safe operation. For that reason voltage stabilizers are became an important part of electrical/electronic equipment. Voltage stabilizers are many types. Out of them the following four types are important.

1. Zenar diode voltage stabilizer.
2. Manuel or non-automatic voltage stabilizer.
3. Automatic voltage stabilizer.
4. Servo voltage stabilizer.

They are available with different ratings such as 0.2 KVA, 0.5 KVA, 1 KVA etc., The capacity of voltage stabilizer can be selected based on the power rating of load.

### 7.11.1 Non - automatic voltage stabilizer

The working of non automatic voltage stabilizer may be understood by studying following circuit diagram. Basically it consists of 8-tap auto transformer, a selector switch, pilot lamp, toggle switch, volt meter and output socket. When the supply is switched ON at N and L, the voltage is selected by rotating the selector switch as per the requirement. Out of eight tappings of the auto transformer three for reducing the voltage, one for same voltage as the line voltage and the rest for increase the voltage when required.

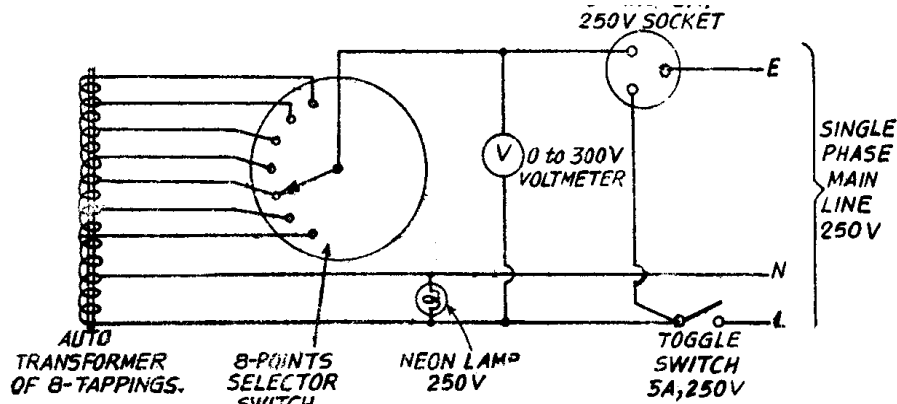

Fig 7.12 Internal connections of non- automatic voltage stabilizer.

### 7.11.2 Automatic Voltage stabilizer

The main transformer has three secondary windings namely 10V-0-10V, 12-V-12V and 20V-0-20V. The 20 V winding provides the boost voltage ( increases the out put voltage ). It comes in series with primary winding to boost the supply voltage. When the input voltage goes high, the relay de-energises and its contact moves to the off position (4) to subtract 10V of the buckling winding. A push button switch connects the volt meter at load terminals to indicate the output voltage.

The 12-0-12 winding is for providing dc to be fed to the electronic control circuit. This electronic circuit activates the relay terminals to switch over different tapping of the transformer based on the input.

### 7.11.3 Servo Voltage Stabilizer

The servo voltage stabilizer provides a smooth and constant output voltage with in a permissible variations in the input voltage. The main components/parts are Auto transformer, Servo motor, voltage sensing circuit, indicators and control switches. When the input voltage is equal to the preset output voltage, the voltage sensing circuit will be inactive. If the value of output voltage is varied due to some reasons, the voltage sensing circuit immediately reacts and drives the servo motor.

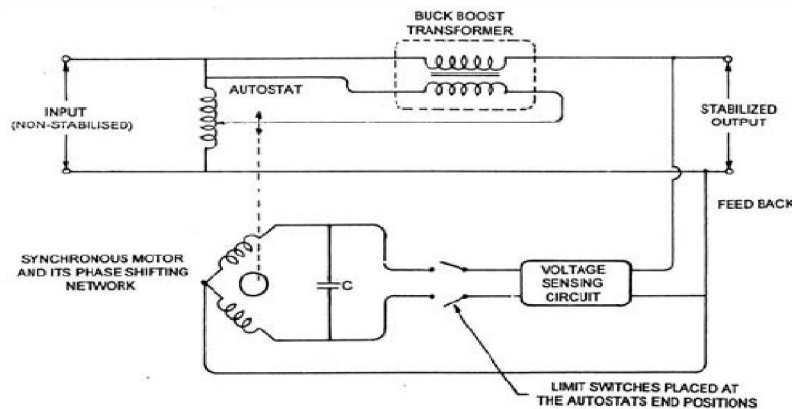

Fig. 7.13 Servo voltage stabilizer

It adjusts the position of sliding terminal/arm on auto transformer in order to get constant voltage at output terminals with associated action of buck-boost transformer. The voltage sensing circuit made by relays, transistors and other electronic components.

### Key Concepts

- Basic concept of Rectifier, Voltage Stabilizer, Inverter and UPS

### Activity

- Identify the nature/name of the power supply being used in various applications like electronic appliances, domestic, commercial and industrial utilities/applications.
- Identification of parts in voltage stabilizer, inverter and UPS
- Assembling of Inverter and UPS.

---

**Short Answer Type Questions**

---

1. Name the different types of power supplies.
2. Define rectifier and name different types of rectifiers.
3. Define filter and list the different types of filters used in Rectifiers.
4. Draw the block diagram for Inverter and UPS
5. What is stabilizer ? Name different types of voltage stabilizers.

---

**Long Answer Type Questions**

---

1. Draw the block diagram of power supply unit and explain about each block
2. Explain the construction and working of Half wave rectifier.
3. Explain the construction and working of Full wave rectifier by using centre tap transformer.
4. Explain the construction and working of full wave bridge rectifier.

---

**On the Job Training/Project Oriented Questions**

---

- Identify the main parts of practical voltage stabilizer, inverter and UPS
- Know the handling/operation methods of inverter, UPS
- Learning the installation of house wiring with inverter power supply.

## Amplifiers and Integrated Circuits

### Learning Objectives

- Amplifier-Definition, purpose and types
- Practical amplifiers
- Integrated Circuits and Discrete Circuits
- Application of Integrated Circuits.

### 8.1 Basic concept on Amplifiers

Almost all electronic systems can work with an amplifier. If a PA system (Public address system) fails, the voice of a singer or melody of the orchestra can't reach the audience in Auditorium. The signal picked up by microphone is enlarged/amplified by an AF amplifier and passed on to a loud speaker. The loud speaker converts the amplified signal to sound wave. In similar manner, the weak signals received by the radio antenna are amplified by RF amplifier. In televisions, the VHF signals received by the antenna were amplified by VHF amplifier. These amplified signals fed to different circuits to produce audible sound or good quality picture.

*Amplifier is an electronic circuit which rises the strength of a weak signal applied at its input terminals and produces amplified/magnified output at its output terminals by utilizing the DC power applied to it.*

The power in the output signal is approximately equal to the sum of the power of input signal and dc power consumed by that amplifier.

## 8.2 Classification of Amplifiers

Amplifiers are classified in various ways. The classification based on various aspects is given below.

(A) According to their primary function.

1. Voltage amplifiers.
2. Current amplifiers.
3. Power amplifiers.

(B) According to the frequency range of operations.

1. Audio frequency amplifiers or AF amplifiers (20 Hz to 20 KHz)
2. Intermediate frequency amplifiers or IF amplifiers (455 KHz)
3. Very High frequency amplifiers or VHF amplifiers (50 Hz to 6MHz)
4. Radio frequency amplifiers or RF amplifiers (30 KHz and above)

(C) According to choice of the condition of operation.

1. Class A amplifier
2. Class B amplifier
3. Class C amplifier
4. Class AB amplifier

(D) According to method of coupling.

1. RC coupled amplifier.
2. LC coupled amplifier.
3. Transformer coupled amplifier.
4. Direct coupled amplifier.

## 8.3 Operation of Transistor as Amplifier

A transistor can perform a number of other functions, but it is mainly used in amplifiers to magnify (amplify) the weak electrical signals.

The following circuit arrangement shows a basic common base amplifier with NPN Transistor.

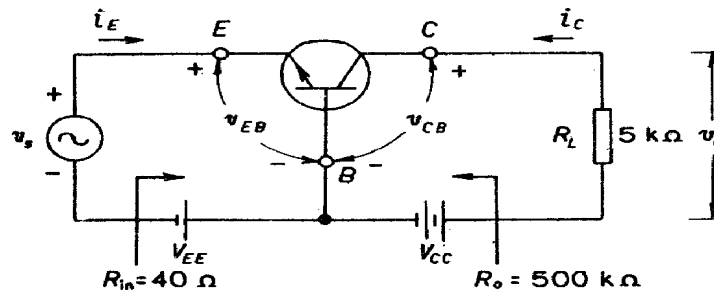

Fig 8.1 Transistor as amplifier

Here the input is applied at emitter base junction (E/B Junction) and the output is taken from collector base junction (C/B junction). The E/B junction is forward biased and the C/B junction is reversed biased.

When the signal  $V_s$  is super imposed on the dc voltage  $V_{EE}$ , emitter base voltage  $V_{EB}$  varies with time resulting current  $I_E$  also varies. This produces similar variations in collector current. This varying current passes through load resistance  $R_L$  and develops varying voltage at  $R_L$  (as  $V_o$ ). The output signal voltage  $V_o$  is many times greater than the input signal voltage  $V_s$ . The transistors amplifying action is basically due to its capability of transferring its signal current from low resistance circuit to high resistance circuit.

#### 8.4 Multistage Amplifiers

An amplifier is the basic building block of most electronic systems. A single stage amplifier is not sufficient to build a practical electronic system. The level of signal can be raised by using more than one stage.

When a number of amplifier stages are used in succession, it is called multistage amplifier. In a multistage amplifier, the output of one stage is applied to another stage (as input) through a coupling network. Based on the coupling methods, there are four types of multistage amplifiers.

- 1). RC coupled amplifier
- 2). Inductive/Impedance coupling
- 3). Transformer coupled amplifier
- 4). Direct coupled amplifier

---

## 8.5 Power Amplifier

The main purpose of power amplifier is to boost the power level of input signal. A power amplifier delivers high power, handles large current and has more gain.

There are different types of power amplifiers. such as

- a) Class - A
- b) Class - B
- c) Class - C
- d) Class AB
- e) Push -Pull amplifier
- f) Complementary symmetry push pull amplifier .

---

## 8.6 Integrated Circuit

The circuits discussed so far consist of separately manufactured components such as Resistors, Diodes, Transistors, Capacitors, Inductors etc., They are joined by wire or soldered to a printed circuit board. Such circuits are known as discrete circuits because each component in the circuit can be separated from others. Discrete circuits have two main disadvantages such as it requires more space, there may be so many soldered points. Considering these problems, integrated circuits are developed.

The first integrated circuit was developed by J.S.Kilby in 1958. Since then various industries have developed a large number of standard integrated circuits.

### What is an Integrated circuit?

An IC is a packaged electronic circuit. It is a complete electronic circuit in which both the active and passive components are fabricated on an extremely tiny single silicon chip.

(Active components - Transistors, FET's, Diodes etc,

Passive components - Resistors, Capacitors, inductors etc.)

---

## 8.7 Advantages of IC's

IC's have many advantages when compared with discrete circuits.

1. **They occupy very small space** : This is due to fabrication of various circuit elements on a single chip of 15  $\mu\text{m}$  thick.



*Chip* : An extremely small part of silicon wafer on which IC is fabricated. One silicon wafer of 2cm dia, may 200  $\mu\text{m}$  thick contain 1000 IC chips.

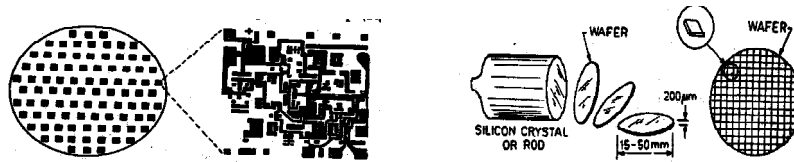

Fig 8.2 Basic structure of chip

2. **Their weight is very less** : Generally a single chip may contain 50 to 300,000 components. Hence their weight is very very less compared with discrete circuits.
3. **They are available at low cost** : All circuit components are fabricated in or on a single wafer. At the same time hundreds of similar wafers can be produced simultaneously. Due to this type of production (called mass production), an IC costs less compared with discrete components.
4. **Increased reliability** : It is due to components are fabricated simultaneously and has no soldered joints and smaller temperature rise on operation.
5. **Low power consumption** : IC's require less power for its operations. Because the circuit components are smaller in size.
6. **Increased performance** : The overall performance of IC is more than discrete circuit. It is faster and can withstand extreme temperatures. And performs functions which are impossible by conventional circuits.
7. **Easy replacement** : It is easy to replace an IC. Because they are being fabricated in single line, dual line plastic package. Hence they can be plugged in to the IC socket directly.

## 8.8 Dis-Advantages of IC's

The integrated circuits suffer with the following draw-backs.

1. Fabrication of inductor on IC is difficult
2. It is not possible to fabricate a Transformer on IC.
3. IC can't be repaired in case of failure.
4. They function at low voltages only.

5. They are delicate and can't stand rough handling or excessive heat.
6. They handle only limited amount of power.

### Classification of Integrated circuits

The integrated circuits can be classified in to three groups.

- A. Classification based on the level of integration.
- B. Classification based on the method of manufacturing.
- C. Classification based on the area of applications mode of operation

#### A. Classification of IC's based on the level of Integration.

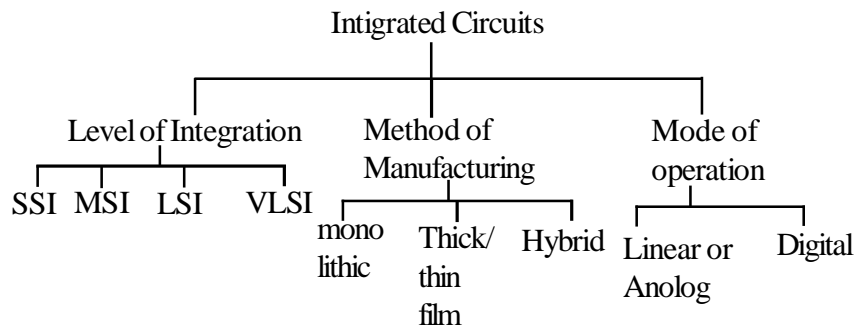

This type of classification is based on number of electronic components or circuits per IC package.

This type of classification is as explained below.

- a) **Small scale integration (SSI)**. The no. of circuits per IC is varied upto 30 or net no. of components are less than 50.
- b) **Medium scale Integration (MSI)**. Here the no. of circuits per IC package is varied between 30 to 100 or 50 to 500 components.
- c) **Large scale integration (LSI)**. The no. of circuits per IC package for this type of integration is varies between 100 to 100,000 or 500 to 300 000 components.
- d) **Very large scale Integration (VLSI)** : It is very large level of integration. The no of circuits per each silicon wafer is more than 1,00,000.

### 8.9 Classification of IC's based on the method of manufacturing.

The IC's can be classified in to three groups on their method of manufacturing/fabrication. They were

a) *Monolithic IC's* : In this, all the circuits/components are fabricated on single silicon wafer. Transistors, diodes, resistors, capacitors etc., are fabricated appropriate spots in the wafer. This type of IC's are in wide use and also most economical.

b) *Thick and thin film IC's* : The physical size and shape of thick and thin film IC's is same. But there is a lot of difference in characteristics and method of fabrication.

This type of IC's accomidates only passive components like resistors, capacitors etc.

c) *Hybrid IC's or multi chip IC's* : This type of IC can be formed by a number of interconnected individual chips/wafers or by combination of film and mono lithic IC techniques. So that, all the components active and passive components can be fabricated in a single IC.

### 8.10 Classification of IC's based on applications/mode of operation.

IC's can be classified in to two groups according to their mode of operation and applications. They were

- a) Linear IC's
- b) Digital IC's

a) **Liner IC's (LIC's)** : These are also refered as analog IC's. Since, their output is praportional to their input. They are much reliable, fast responding. Linear IC's are equilent to general discrete circuits such as amplifier, filter, oscillator, modulator, demodulator etc., The major applications of linear IC's are

- a) Operational amplifiers (CA 741 CT, LM 208)
- b) Small signal amplifiers 9TEA 5591)
- c) Power amplifiers (CA 3020)
- d) RF and IF amplifiers (CA 3065)
- e) Micro wave amplifiers

- f) Multipliers
- g) Voltage comparators CA 741 T
- h) Voltage regulators (ICI 723)

**b) Digital IC's :** This type of IC's are used in computers. But its utilization is extended to other electronic equipments also. Basically digital IC's are monolithic type. Digital IC's contain circuits whose input and output voltages are limited to two levels 'low' or 'high'. The applications of digital IC's are

- a) logic gates b) Flip-flaps c) Counters d) clocks/timers
- e) Calculators f) Memory chips g) Micro processors.

### 8.11 Identification of IC terminals/pins

After the completion of fabrication of different components on a chip, it is arranged in a package as shown in fig. Usually ceramic packages are used where IC is subjected to high temperature. In general, plastic material is used as package material for IC's. Eventhough there is a standardize IC terminal connections, various manufacturers use their own systems for pin identification. But most of the manufacturers use the pin diagrams for IC package as shown in fig.

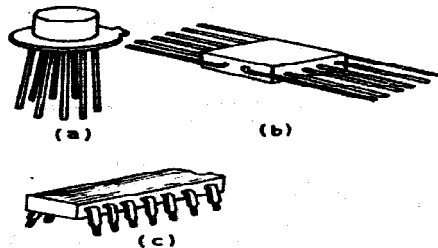

Fig 8.3 Different physical shapes of Integrated Circuits

#### Flat package

1. Count starts with pin where dot is located
2. Count proceeds in direction as arrow indicated.



Fig 8.4 Flat pack

**To package**

1. Count starts with the pin left of the tab.
2. Count proceeds in anti-clock wise direction as arrow indicated.



Fig.8.5 To-package-

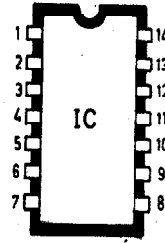

Fig 8.6 Dual In Line

**Dual in line plastic package**

1. Count starts with pin which is left of notch
2. Count proceeds as the direction of arrow.

**Key Concepts**

- Familiarisation of Amplifiers – PA amplifier.
- Basic Idea on Integrated Circuits and their applications.

**Activity**

- PA Amplifier, Cable TV amplifier functions and connections
- Integrated Circuits – identifications and pin diagram
- Collect IC's from old calculators, mobile phones other electronic devices and try to collect some information.
- Connecting methods of Integrated Circuits in PCB

**Questions**

1. How the amplifiers can be classified ?
2. How a transistor amplifier the weak signal ? Explain in detail.
3. Define IC.
4. What are the advantages of IC's
5. What are the liminations of IC's

6. Define chip.
7. Classify the IC's
8. What are the applications of linear/Analog and digital IC's
9. Compare at least aspects between discrete circuits Integrated circuits.
10. Mention the types of packages used for IC's.

---

**On the Job Training/Project Oriented Questions**

---

- Visit a nearby event management/PA System hirer know different equipments which they are using.

## Fibre Optics - Basic Concepts

### Learning Objectives

- Role of fibre optics in communication system
- Fibre optic cables

### 9.1 Introduction

Fiber-optic communication is a method of transmitting information from one place to another by sending pulses of light through an optical fiber. First developed in the 1970s, fiber-optic communication systems have revolutionized the telecommunications industry and have played a major role in the advent of the Information Age.

That tiny strand of optical fiber can carry more communications signals than the large copper cable in the background and over much longer distances. The copper cable has about 1000 pairs of conductors, can only carry about 24 telephone conversations a distance of less than 3 miles. The fiber cable carries more than 32,000 conversations hundreds or even thousands of miles before it needs regeneration. Then each fiber can simultaneously carry over 150 times more by transmitting at different colours (called wavelengths) of light.

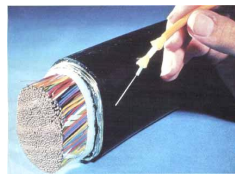
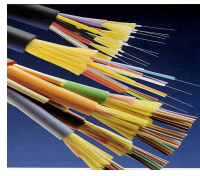

9.1 Fiber Optic cables

The cost of transmitting a single phone conversation over fiber optics is only about 1% the cost of transmitting it over copper wire! That's why fiber is the exclusive medium for long distance communications.

Because of its advantages over electrical transmission, optical fibers have largely replaced copper wire communications in core networks in the developed world.

But the Optical fiber cannot be join together as easily as copper cable. It requires training and expensive splicing and measurement equipment.

The process of communicating using fiber-optics involves the following basic steps:

- Creating the optical signal involving the use of a transmitter,
- Relaying the signal along the fiber,
- Strengthening the signal if distorted or weak,
- Receiving the optical signal, and converting it into an electrical signal

---

## 9.2 Applications

Optical fiber is used by many telecommunications companies to transmit telephone signals, Internet communication, and cable television signals, LANs - local area networks, CATV - for video, voice and Internet connections, Utilities closed-circuit TV circuits etc.,

---

## 9.3 Technology

Modern fiber-optic communication systems generally include an optical transmitter to convert an electrical signal into an optical signal to send into the optical fiber, a cable containing bundles of multiple optical fibers that is routed through underground conduits and buildings, multiple kinds of amplifiers, and an optical receiver to recover the signal as an electrical signal. The information transmitted is typically digital information generated by computers, telephone systems, and cable television companies.

Fiber optic transmission systems all consist of a transmitter which takes an electrical input and converts it to an optical output from a laser diode or LED. The light from the transmitter is coupled into the fiber with a connector and is transmitted through the fiber optic cable plant.

The light is ultimately coupled to a receiver where a detector converts the light into an electrical signal which is then conditioned properly for use by the receiving equipment. Just as with copper wire or radio transmission, the



performance of the fiber optic data link can be determined by how well the reconverted electrical signal out of the receiver matches the input to the transmitter.

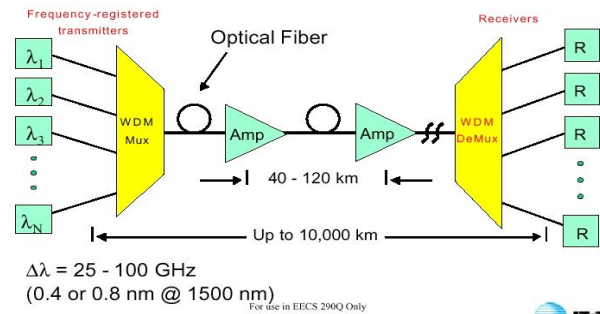

## 9.2 Fiber Optic Technology

### 9.4 Transmitters

The most commonly-used optical transmitters are semiconductor devices such as light-emitting diodes (LEDs) and laser diodes. The difference between LEDs and laser diodes is that LEDs produce incoherent light, while laser diodes produce coherent light. For use in optical communications, semiconductor optical transmitters must be designed to be compact, efficient, and reliable, while operating in an optimal wavelength range, and directly modulated at high frequencies. In its simplest form, an LED is a forward-biased p-n junction, emitting light through spontaneous emission, a phenomenon referred to as electroluminescence. The emitted light is incoherent with a relatively wide spectral width of 30-60 nm. LED light transmission is also inefficient, with only about 1 % of input power, or about 100 microwatts, eventually converted into launched power which has been coupled into the optical fiber. However, due to their relatively simple design, LEDs are very useful for low-cost applications. Furthermore, semiconductor lasers can be modulated directly at high frequencies because of short recombination time.

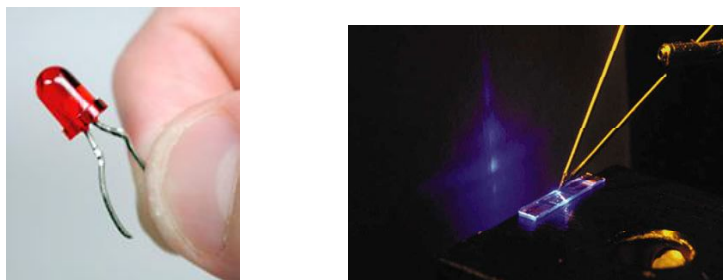
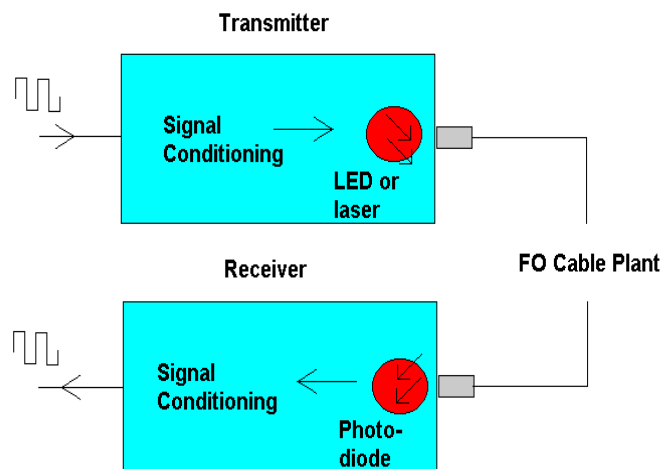

Fig 9.3 LED and ILD (injection laser diode)

Commonly used classes of semiconductor laser transmitters used in fiber optics include VCSEL (Vertical Cavity Surface Emitting Laser), Fabry–Pérot and DFB (Distributed Feed Back). Laser diodes are often directly modulated, that is the light output is controlled by a current applied directly to the device. For very high data rates or very long distance links, a laser source may be operated continuous wave, and the light modulated by an external device such as an electro-absorption modulator or Mach–Zehnder interferometer. External modulation increases the achievable link distance by eliminating laser chirp, which broadens the line width of directly-modulated lasers, increasing the chromatic dispersion in the fiber.

## 9.5 Receivers

The main component of an optical receiver is a photodetector, which converts light into electricity using the photoelectric effect. The photodetector is typically a semiconductor-based photodiode. Several types of photodiodes include p-n photodiodes, p-i-n photodiodes, and avalanche photodiodes. Metal-semiconductor-metal (MSM) photodetectors are also used due to their suitability for circuit integration in regenerators and wavelengthdivision multiplexers. Optical-electrical converters are typically coupled with a transimpedance amplifier and a limiting amplifier to produce a digital signal in the electrical domain from the incoming optical signal, which may be attenuated and distorted while passing through the channel. Further signal processing such as clock recovery from data (CDR) performed by a phase-locked loop may also be applied before the data is passed on.



9.4 Block diagram of Transmission and reception Optic fiber communication



Fig 9.5 APD (Avalanche photo diodes)

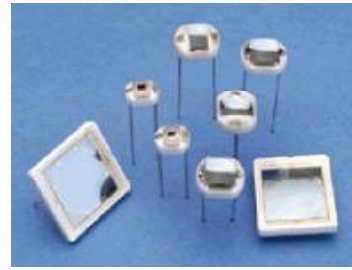

Fig 9.6 PIN (Positive Intrinsic Negative)

## 9.6 Fiber Cable

### Types of Fiber Optic Cables:

There are three types of fiber optic cable commonly used

- Single mode fiber
- Step index multimode fiber
- Plastic mode fiber

### Single mode

- Diameter of 8.3 to 10 microns., fairly narrow diameter
- It will propagate typically 1310 or 1550nm
- higher transmission rate (up to 50 times more distance than multimode)
- Cost more than multimode.

### Step-index Multimode fiber

- made of glass fibers.
- diameter in the 50 to 100 micron range
- multiple paths of light can cause signal distortion at the receiving end, result in unclear or incomplete data transmission.

### Plastic optic fiber

- POF is strong and very difficult to bend.
- POF is not suitable for long-distance transmission
- POF transmits very little infrared light
- It can used for cold lighting or lighting displays of artwork

Optical fiber is comprised of a light carrying core surrounded by a cladding which traps the light in the core by the principle of total internal reflection. Most optical fibers are made of glass, although some are made of plastic. The core and cladding are usually fused silica glass which is covered by a plastic coating called the buffer or primary buffer coating which protects the glass fiber from physical damage and moisture. There are some all plastic fibers used for specific applications. Glass optical fibers are the most common type used in communication applications.

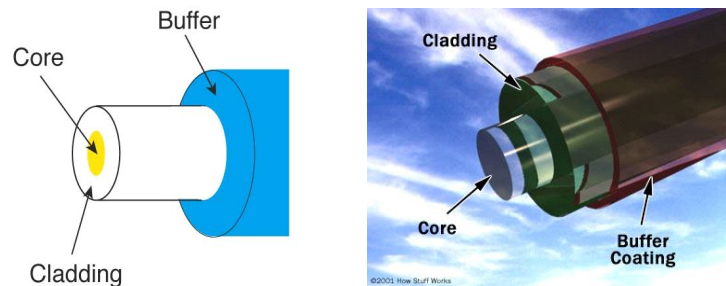

**Fig 9.7 Construction of Fiber Optic cable**

Optical fibers are enclosed in cables for protection against the environment in which they are installed. Cables installed in trays in buildings require less protection than, for example, cables buried underground or placed under water.

The outside of the cable is called the jacket. It is the final protection for the fibers and must withstand extremes of temperatures, moisture and the stress of installation. Some cables even have a layer of thin metal under the jacket to prevent rodents from chewing through the cable. The colors you see above are color-coding so you can identify individual fibers in the cable.

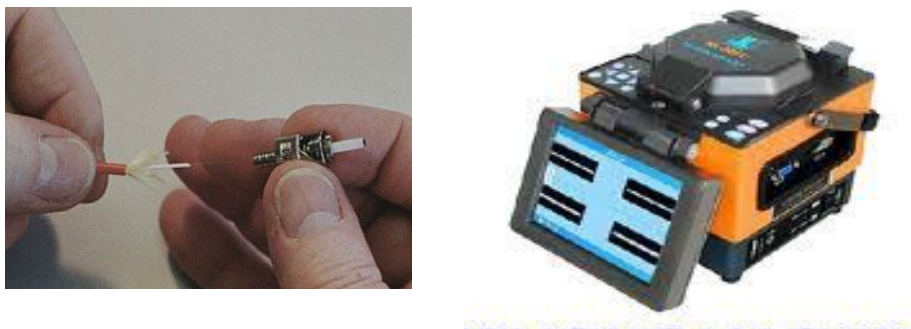

**Fig 9.8 Splicing of fiber optic cables**

When a fiber needs to be connected to another, it can be spliced permanently by “welding” it at high temperatures or with adhesives, or it can be terminated

with a connector that makes it possible to handle the individual fiber without damage. Connectors align two fibers the size of a human hair such that little light is lost. Most connectors use ceramic cylinders about 2.5 mm in diameter with precisely aligned holes in the center that accept the fiber. Most connectors use adhesive to attach the fiber and the end is polished to a smooth finish.

Putting connectors on the end of fibers is a job that requires patience, skill and good training. Fiber optic technicians are expected to be able to install connectors properly.

---

### **Key Concepts**

- Fiber optic cables basic concepts

---

### **Activity**

- Observe fiber optic cables used in cable tv and internet cable

---

### **Short Answer Type Questions**

1. Write the applications of fiber optic cables?
2. Name different types of fiber optic cables.
3. How the fiber optic cables can be joined?

---

### **On the Job Training/Project Oriented Questions**

Observe different fiber optic cables used at OJT site

Assist in installation and servicing of fiber communication system.